



11591 Watertank Rd.
Burlington, WA 98233
Telephone: 1.360.757.8601
Fax: 1.360.757.4401
www.teamcorporation.com

Structural Developments Improve High-Frequency Vibration Testing on a CUBE Multi-Axis System

84th Shock and Vibration Symposium, Atlanta, GA, November 3-7, 2013

Author: Joel Hoksbergen¹, Bill Woyski

Revision: A

Abstract:

The frequency response of a multiple-input, multiple-output (MIMO) vibration test system is typically limited by the dynamic response of the table structure between the vibration exciters and the test payload. The primary design goal in developing this structure is to minimize the moving mass and maximize the stiffness to give the highest possible first vibration mode, while realizing all other structural requirements. Many Department of Defense random vibration test profiles have a 500 Hz bandwidth, and depending on the system and test article, often the first mode of the loaded table structure must be outside of the test bandwidth to adequately control the test. This is a challenging requirement when the vibration system is multi-axis and the test spectra are excited simultaneously on all axes. Team Corporation addressed these issues with a special version of the Cube six degree-of-freedom (6-DOF) vibration test system. The challenges of the design requirements and the development of a structure with a frequency response that exceeds 500 Hz are discussed. Additionally, test results from the MIL-STD-810G Common Carrier random vibration profiles are presented for the final design and for two of these Cubes operated simultaneously with a bridging test article.

¹Joel Hoksbergen, Team Corporation, 11591 Watertank Rd., Burlington, WA, 98232, joel.hoksbergen@teamcorporation.com

Contents

1	Introduction	2
2	Design Requirements.....	3
3	Original Design.....	5
3.1	Response of Original Design	5
3.2	Operating Deflection Shapes	6
4	Redesigned Structure.....	8
4.1	Design Approach.....	8
4.2	Design Fundamentals.....	8
4.3	Detailed Design	9
5	Single Cube Test Results	11
6	Dual Cube Test Results.....	13
7	Conclusions	16
8	References	16

List of Figures

Figure 1: Standard Model 4 Long Stroke	3
Figure 2 : Required Test Profiles – MIL-STD-810G Method 514.6 Annex C Common Carrier	4
Figure 3: Original Design Approach	5
Figure 4: Bare Table Response of the Original Design for Longitudinal, Transverse, and Vertical Profiles..	6
Figure 5: 364 Hz Operating Deflection Shape	7
Figure 6: 450 Hz Operating Deflection Shape.....	7
Figure 7: Integrated Structure Concept (outer skins removed for clarity)	9
Figure 8: Redesign First Elastic Mode	10
Figure 9: Redesign Second Elastic Mode	10
Figure 10: Redesign Longitudinal, Transverse, and Vertical Bare Table Test Results.....	12
Figure 11: Dual Cube Bridged Configuration	13
Figure 12: Dual Bridged Cube Longitudinal, Transverse, and Vertical Response	15

List of Tables

Table 1: MIL-STD-810G Method 514.6 Annex C Common Carrier Profiles.....	4
Table 2 : Design Comparison.....	10
Table 3: Bridging Test Article Specifications	13

1 Introduction

Of Team Corporation’s Multi-Axis vibration test solutions, the six degree-of-freedom (6-DOF) Cube system is one of the most popular. The Cube uses 6 internal servo-hydraulic actuators that work as orthogonal pairs to accurately replicate all six degrees-of-freedom of the payload mounting surface, which for this system is a cube shaped magnesium box. The actuators provide control over all three translational and rotational DOF of the box structure. This Cube comes in a variety of models with varying strokes and frequency responses to accommodate customer requirements.

Team Corporation was approached by a vibration test lab of the United States Navy¹ to provide a Long-Stroke version of the Cube with a frequency response of 5-500 Hz and a 60 inch by 60 inch top mounting surface. This was an aggressive target for this large of a structure, but not outside of the actuator and servo valve capabilities. The most difficult aspect would be a structure stiff enough for this test bandwidth.

The original design solution presented was the long stroke version of the Cube with Team Corporation’s high-frequency V-140IS servo valves driving each actuator, providing the best frequency response from the actuators. The large payload mounting surface would be created with a bolt on head expander structure. The following table lists the standard specifications for this model of the Cube.

Long Stroke Cube Specifications	
Force per Axis (3,000 psi Oil Supply)	14,000 lbf sine-peak 7,000 lbf random-rms
Force per Axis (4,000 psi Oil Supply)	18,700 lbf sine-peak 9,350 lbf random-rms
Vertical Stroke	4 inches peak-peak
Horizontal Stroke	2 inches peak-peak

The bolt-on head expander was found to have several modes below 500 Hz and, therefore, did not satisfy the customer’s test requirements. This drove a complete redesign of the basic Cube table structure. This paper discusses the technical difficulties of the original design and how this lead to the redesigned system developed by Team Corporation to provide a large 6-DOF vibration test system with a frequency response out to 500 Hz.

¹ Facility Title: Naval Surface Warfare Center Indian Head Explosive Ordnance Technology Division Detachment Picatinny (NSWC IHEODTD DET PICA), Naval Packaging, Handling, Storage, and Transportation (PHST) Center

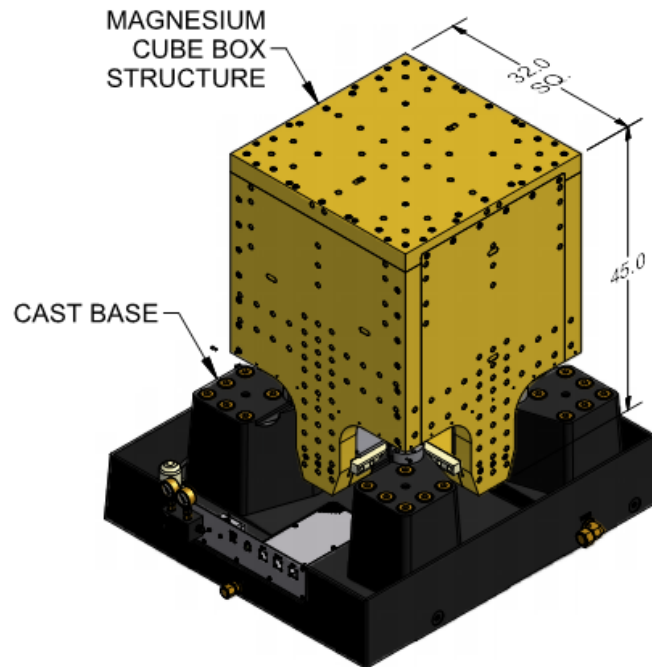

Figure 1: Standard Model 4 Long Stroke

2 Design Requirements

The customers' requirements were to simultaneously replicate all three Common Carrier profiles defined in MIL-STD-810G Method 514.6 Annex C (1). The profile breakpoints are shown in Figure 2 and listed in Table 2. The customer further required the ability to mount a test article that spanned between two separate Cube systems. This meant that the two Cubes effectively had to operate as a single 6-DOF system to prevent damaging the test article.

The Common Carrier set of random profiles has a bandwidth of 10-500 Hz, with the option of operating down to 5 Hz by extending the 10 Hz breakpoint flat to 5 Hz. A subtlety of this set of profiles is that the transverse axis is considerably lower than both the vertical and longitudinal axes. When testing one axis at a time, this detail poses little difficulty. However, when the profiles are excited simultaneously it becomes more difficult to maintain control of the lowest level axis as it can be easily affected by the cross axis motion of the other two axes. The control of this axis degrades further if the test structure has a natural frequency within the test bandwidth. However, exciting all axes simultaneously is the primary advantage of using a MIMO vibration test system like the Cube. There is increasing research into how a component behaves when tested using a 6-DOF system and how this compares with a single axis test. In reality, products exist in a 6-DOF environment. So, having the ability to accurately replicate multi-axis environments is becoming extremely important. This was a driving factor in developing the dual Cube systems.

Table 1: MIL-STD-810G Method 514.6 Annex C Common Carrier Profiles

Longitudinal (X-Axis) 0.74 grms		Transverse (Y-Axis) 0.20 grms		Vertical (Z-Axis) 1.04 grms	
Frequency (Hz)	PSD (g ² /Hz)	Frequency (Hz)	PSD (g ² /Hz)	Frequency (Hz)	PSD (g ² /Hz)
10	.00650	10	.00013	10	.01500
20	.00650	20	.00065	40	.01500
120	.00020	30	.00065	500	.00015
121	.00300	78	.00002		
200	.00300	79	.00019		
240	.00150	120	.00019		
340	.00003	500	.00001		
500	.00015				

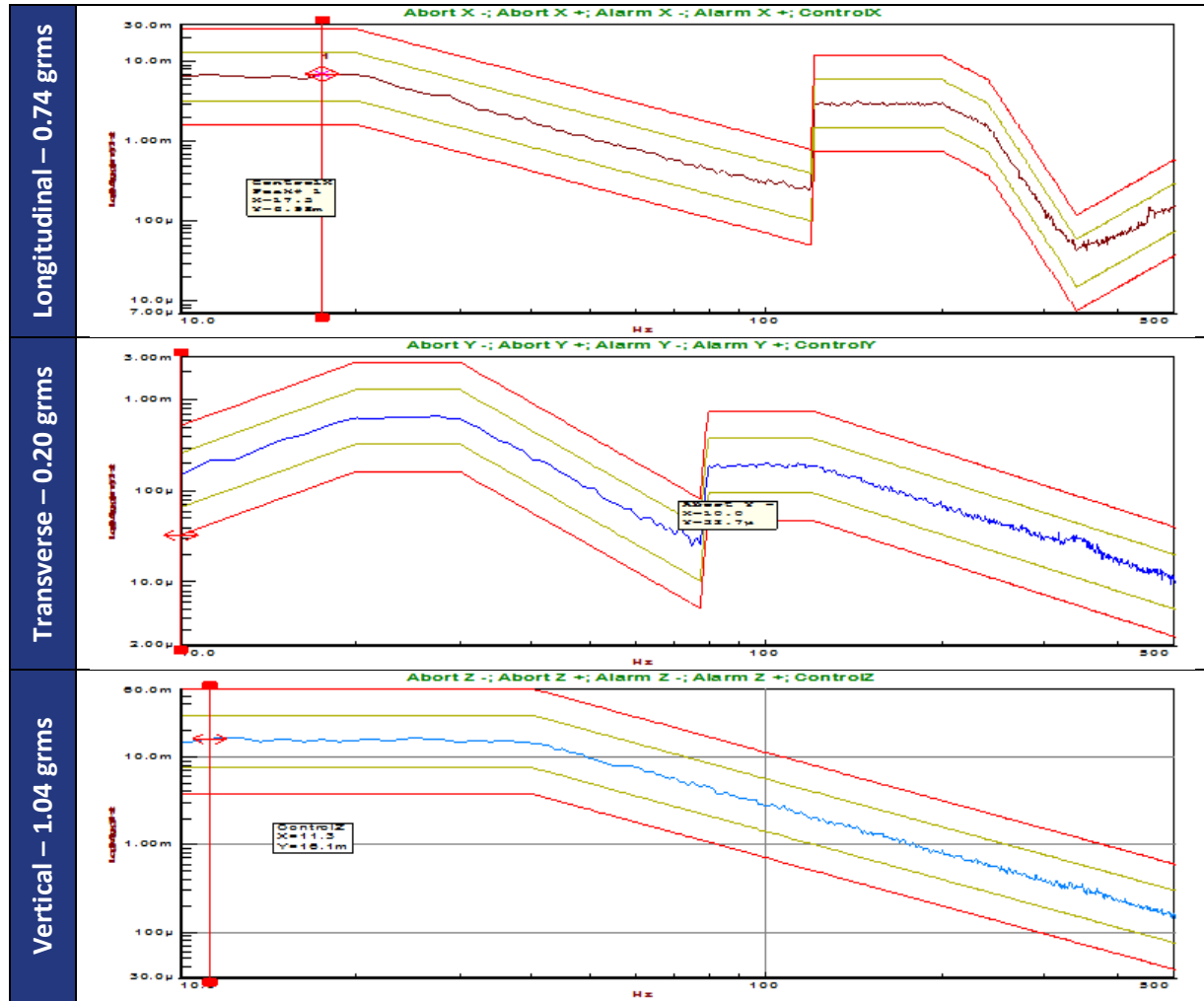

Figure 2 : Required Test Profiles – MIL-STD-810G Method 514.6 Annex C Common Carrier

3 Original Design

The original design proposed and developed for the customer began with a standard Model 4 Cube structure and added additional structures to stiffen the box and provide the 60 in. working surface. Welded structures were bolted onto the bottom sections of the box to stiffen this region, which was known to be the most compliant portion of the structure. In addition, a 60 in. octagonal top plate was mounted to the box top surface with additional welded structures that tied the overhanging portion of the octagonal plate back to the sides of the box. The intent was to keep the moving mass of the top head expander surface down and add structure to apply the appropriate stiffness. The goal of this design approach was to use the standard Cube box as the basis of the design and add additional structure as needed to meet the requirements. This is a technique that has been successful on other lower frequency versions of the Cube. Figure 3 shows the original structure.

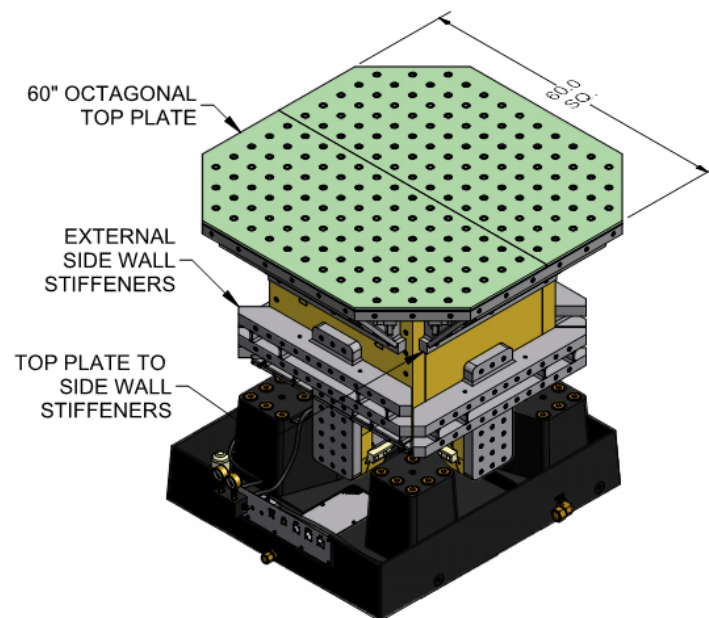

Figure 3: Original Design Approach

3.1 Response of Original Design

Over the course of testing the original system, two natural frequencies of the Cube structure were found to be uncontrollable. The system was investigated in depth, with a variety of techniques applied to damp out the response at these frequencies. All attempts to damp out the response of these modes proved unsuccessful. The fundamental modes occurred at approximately 370 Hz and 455 Hz and were predominantly in the z-axis response. The control of the two horizontal profiles remained within the +3dB tolerance levels, although the response of these two modes could be found in both profiles. The mode at 370 Hz exceeded the z-axis reference level by a factor of 6.73 (+8.3 dB) and the mode at 454 Hz by a factor of 11.78 (+10.8 dB). Figure 4 shows the response of all three axes with the large vertical responses highlighted. Having an uncontrollable mode of the structure was a fundamental concern from the beginning of the design.

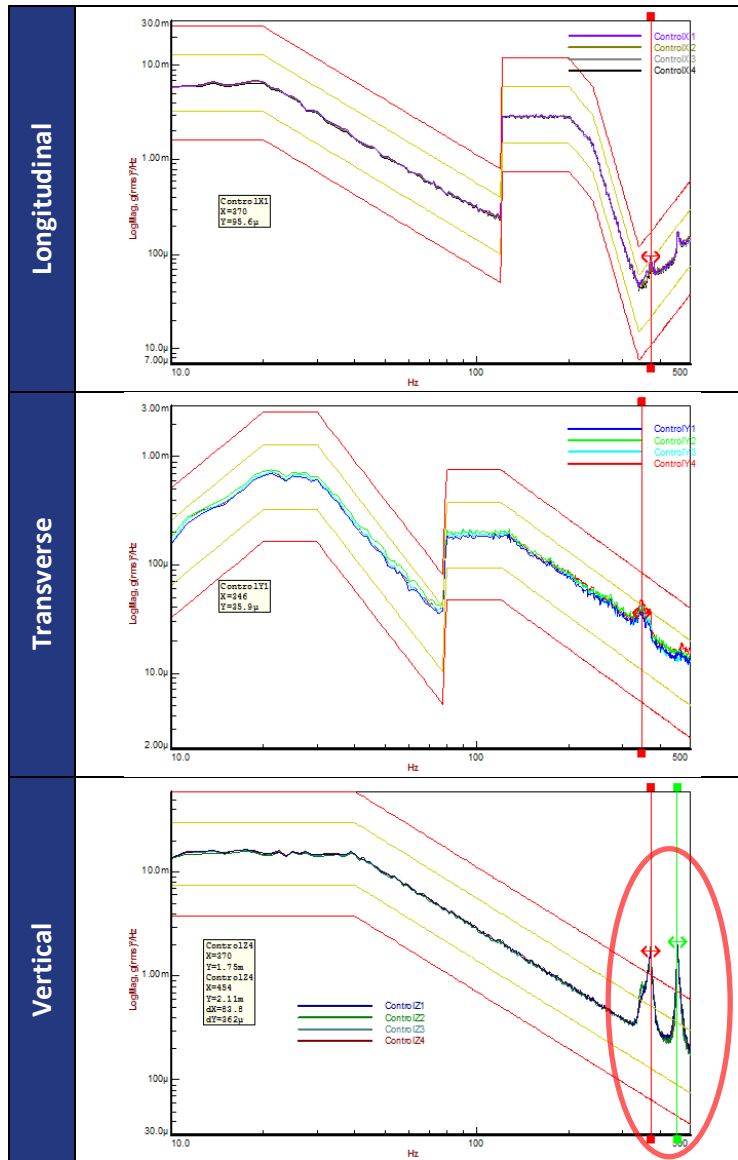

Figure 4: Bare Table Response of the Original Design for Longitudinal, Transverse, and Vertical Profiles

3.2 Operating Deflection Shapes

To better understand what was causing the high response in the structure, a very simple experimental modal analysis of the top surface was conducted. Four tri-axial accelerometers were placed near the outside of the octagonal top plate and one single axis accelerometer was placed at the center as the reference for the transfer function measurements. The software package ME'ScopeVES was used to analyze and animate the collected transfer function data and determine the Operating Deflection Shapes (ODS).

Looking at the ODS of the model at the two difficult frequencies revealed the following plots in Figure 5 and Figure 6. The ODSs are difficult to visualize without being animated (i.e. as a plot in this report), however in the ME'ScopeVES software it is plain to see that the first shape is a torsion/flexural mode at 364 Hz. The shape is the typical first mode of a free-free plate, where adjacent corners of the structure are moving out of phase in the vertical direction. The second shape looks more like a rigid body rolling

mode when animated. However, based on previous modal analyses and finite element models (FEM) of Cube structures, the animated ODS at 450 Hz indicated that it was a shape typical of the Cube box structure. This shape is characterized by the structure bending about a line in the middle region of the structure, producing a shape where both the top plate and bottom plate are rolling out of phase to each other with the structure between bending to accommodate the motion. An analogy would be to apply a moment to a flexible three-dimensional structure such as a soda can. The top and bottom will roll towards each other, while the center bends (or buckle if compliant enough) to accommodate the rolling motion. The results from the modal analysis produced a firm understanding of the uncontrollable mode shapes and generated ideas for increasing the overall stiffness of the Cube structure. The results from this testing prompted a detailed design review with the end result being a redesigned structure proposed to the customer.

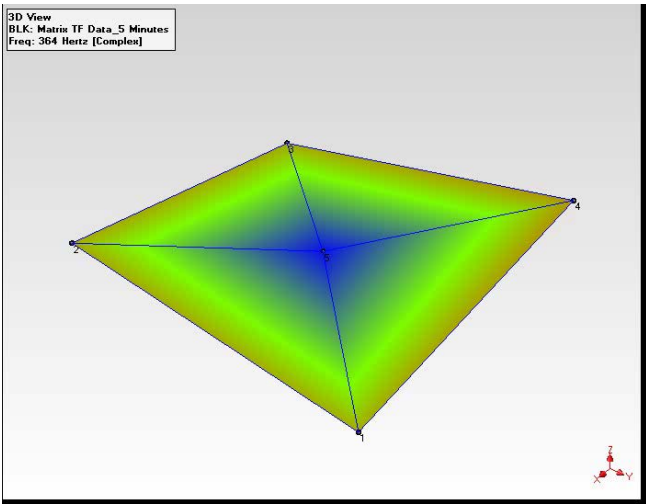

Figure 5: 364 Hz Operating Deflection Shape

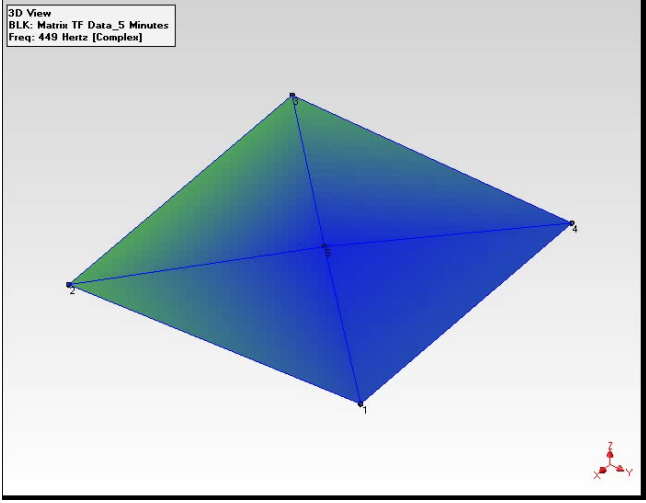

Figure 6: 450 Hz Operating Deflection Shape

4 Redesigned Structure

4.1 Design Approach

Since the mode shapes for the uncontrollable modes were known, and from previous knowledge of Cube structures, a general design approach was developed to increase the area moments of inertia in order to increase the bending and torsional stiffness of the overall structure. For this particular test, the weight budget was not a constraining factor, because the system had excess force to perform the vibration test. However, every attempt was made to minimize the moving mass of this much larger structure so that the force margin could be maintained as much as possible.

4.2 Design Fundamentals

To understand the design methodology of the new structure, it is necessary to first look at the governing equations for the natural frequencies of simple structures and to apply this understanding to the design of the advanced structure. Consider the free-free vibration of a rectangular plate. An analytic solution for the natural frequency is known in plate theory for a variety of boundary conditions. For the free-free case of a square plate the natural frequencies can be calculated using the following equation (Blevins, p. 253):

$$f_{ij} = \frac{\lambda_{ij}^2}{2\pi a^2} \sqrt{\frac{Eh^3}{12\rho h(1-\nu^2)}} = \frac{\lambda_{ij}^2 h}{2\pi a^2} \sqrt{\frac{E}{12\rho(1-\nu^2)}}$$

Here, E , ν , and ρ are the modulus of elasticity, Poisson's ratio, and mass density, respectively, for the material. The thickness and side dimensions of the plate are defined by h and a , respectively. In this equation, λ_{ij}^2 is a coefficient term that provides for different boundary conditions, mode shapes, and aspect ratios of the plate. Refer to Blevins for a table of coefficient values for different conditions (Blevins, p.253-261). In the case of this design problem, all parameters, except for the thickness, are fixed by the requirements. Applying this to the simple case in the equation, the most effective way to increase the natural frequency of the plate is to increase its thickness, because the natural frequency increases linearly proportional to the thickness. Considering then the given design problem, an effective means to increase the first mode of the Cube structure would be to increase the effective thickness of the top mounting surface.

Similar reasoning can be applied to the second uncontrollable mode of the Cube structure. Recall that this mode shape is characteristic of a structure in bending. Consider then the fundamental equation for the vibration of a beam in bending. The natural frequency equation is given by (Blevins, p. 108):

$$f_i = \frac{\lambda_i^2}{2\pi L^2} \sqrt{\frac{EI}{m}}$$

In this equation, E , I , m , and L are the modulus of elasticity, area moment of inertia, mass, and length of the beam, respectively. In the case of the Cube, E and L are fixed, so the available parameters available to increase the bending natural frequency are increasing the area moment of inertia and decreasing the total mass. Typically, this is an iterative process because increasing the area moment of inertia, in

general, will increase the mass. However, the lesson to be taken from this equation is that optimizing the area moment of inertia to be as large as possible while minimizing the total mass of the structure will create the stiffest possible structure, and in turn, the highest possible natural frequency.

4.3 Detailed Design

Using these fundamentals as a guide, the design approach then became one of optimizing the increase in both the overall thickness of the structure and the area moment of inertia and minimizing the total mass. This approach led to the concept depicted in Figure 7. In this design, the top mounting surface (traditionally called the head expander) has been integrated into the overall Cube 'box' structure that houses the actuators.

The integration of an effectively thick structure and large area moment of inertia with minimal weight is accomplished with the use of a webbed structure that was built up around the Cube's box structure. In addition to increasing the moment of inertia, the webbing also provided a backing structure to the top mounting surface, increasing its flexural stiffness. The web was designed to use minimum thicknesses throughout while maintaining the desired stiffness. The thickness and spacing of the webbing were optimized such that the local vibration modes of any plate were outside the frequency bandwidth and positioned to provide enough localized stiffness behind the actuators to properly transmit the actuator excitation force into the customer's mounted payload.

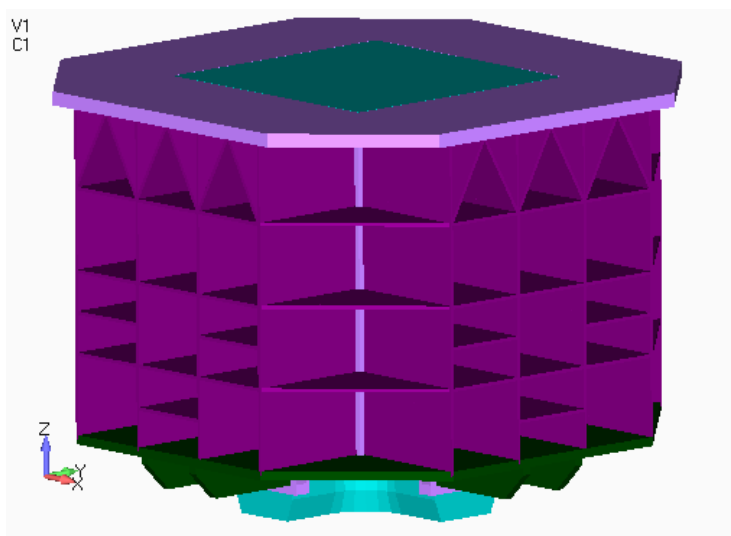

Figure 7: Integrated Structure Concept (outer skins removed for clarity)

A Finite Element Model (FEM) was created of the structure using FEMAP/NxNastran. The model used plate elements for the components less than one inch and solid elements for all other thicknesses. Bolted joints were modeled using linear contact elements and the model was connected to six ground points via spring elements sized to simulate the actuators. The following table compares the FEM results for the redesign to the ODS results of the original design. The data shows that the design increased the first mode shape frequency by 43% to 522 Hz and the second mode shape of the original design by 64% to 737 Hz. The new design had a second mode shape at 605 Hz that was not present in the original design. The mode shapes are shown in the following figures.

Table 2 : Design Comparison

Design Comparison – Bare Box Elastic Modes			
	Redesign FEM (Hz)	Original Design ODS (Hz)	Redesign Mode % Difference
1st Mode	522	364	43%
2nd Mode	605	N/A	N/A
3rd Mode	737	450	64%

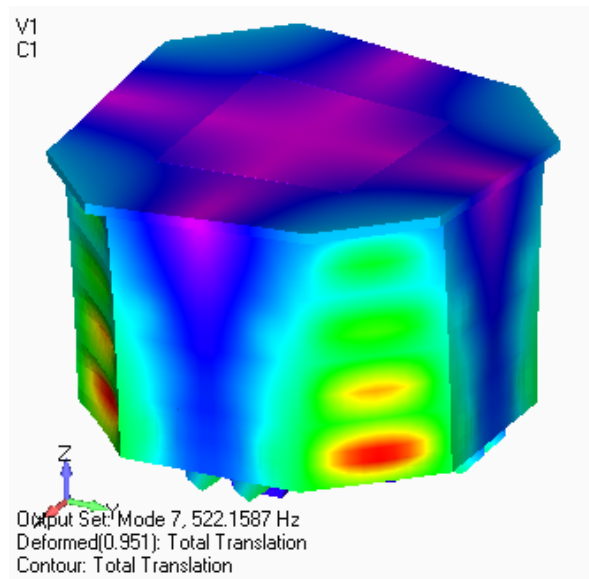

Figure 8: Redesign First Elastic Mode

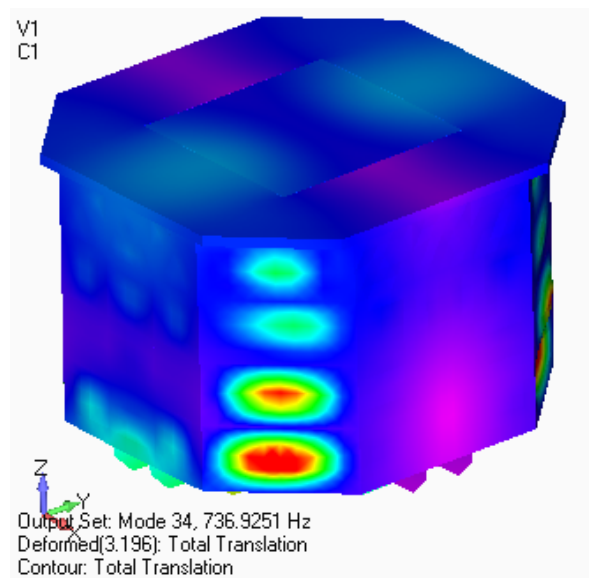

Figure 9: Redesign Second Elastic Mode

5 Single Cube Test Results

The results from the FEM provided confidence in the redesigned structure and after presenting the design to the customer's approval, the integrated head expander was manufactured and assembled on the Cube actuator package. The customer's desired random profiles were run on the Cube system with all three axes excited simultaneously.

The control points for the test were located at the corners of the head expander top surface, on a 48-inch square. A tri-axial accelerometer was placed at each control point, and all three acceleration measurements were used. A total of twelve accelerometer measurements were used for the control of the structure's 6-DOF.

Figure 10 plots the results for all three axes from 5-500 Hz. It should be noted when comparing this figure to Figure 4 that the profiles now extend down to 5 Hz. This figure shows that significant improvements were achieved in the vertical control profile. The resonances at 364 and 470 Hz are completely gone and now excellent control in this axis is maintained over the full bandwidth. This result validates what was predicted by the FEM that the first natural frequency of the new structure would be above 500 Hz.

The control in the longitudinal axis also improved with the increased first mode and the bandwidth above 300 Hz now shows very nice control. The transverse response shows some deviation between 300-400 Hz but remains within the ± 3 dB tolerance lines. There is one frequency at 9 Hz where the response exceeds the tolerance limits but remains within the abort levels. The transverse profile is the lowest level of the three profiles and at this frequency the control level is roughly 100 times lower than the other axes. Most likely there is a rigid body mode in the setup, possibly the reaction mass on air springs, and this level of vibration is approaching the noise level of the system making it difficult to control.

This problem, in which the acceleration level in one axis is considerably lower than the other axes is unique to multi-axis testing. When one level of the three is considerably lower than the others, the system has the most difficulty controlling this low level profile. This is because even low level cross-axis motion from the other profiles can be on the same order of magnitude as the required excitation level of the low profile. However, when running the low level profile as a single axis test only the system produces much better results because it is not being affected by the two higher level tests operating at the same time. It is a result that must be considered when moving from sequential to simultaneous testing and research must be done to determine acceptable levels for error tolerances on the low level profile. MIL-STD-810G, Method 527 Annex C (3) addresses this particular test situation, and provides guidelines that allow the axes with higher acceleration levels to weigh more heavily in the evaluation of the quality of control. The authors are currently researching how best to apply this method to MIMO testing.

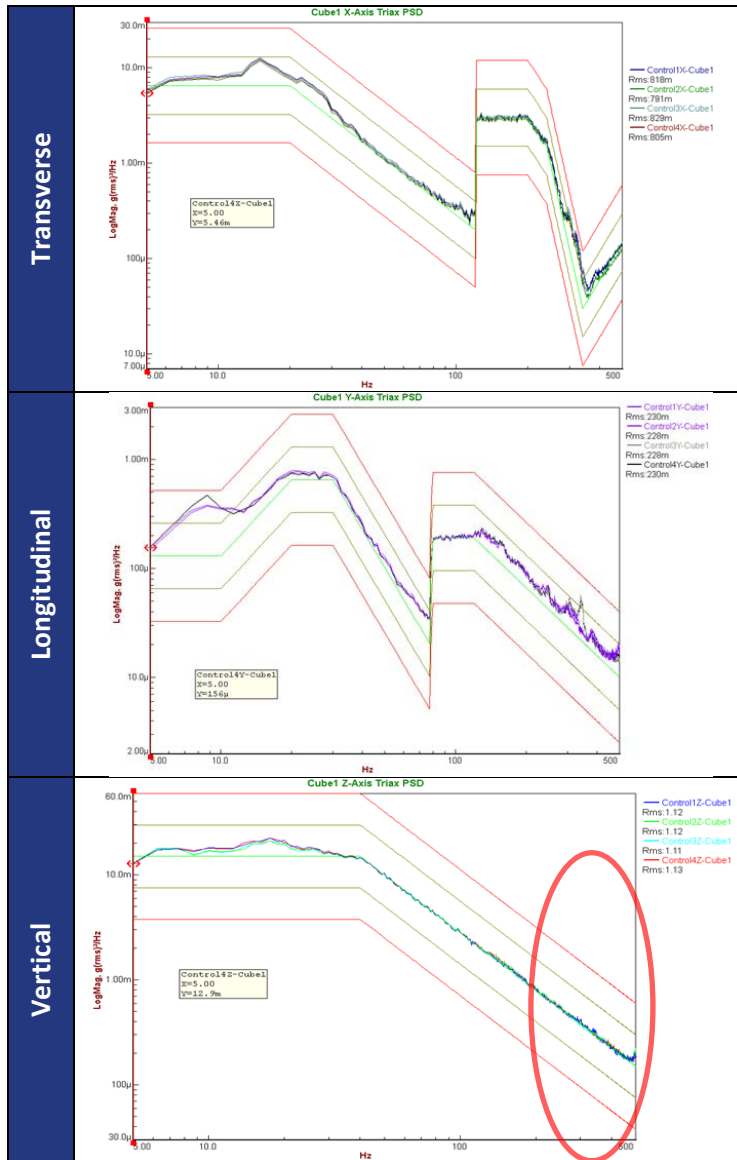

Figure 10: Redesign Longitudinal, Transverse, and Vertical Bare Table Test Results

6 Dual Cube Test Results

With the excellent results attained on the bare table testing of the new structure, the project progressed into operating the dual Cubes as a single 6-DOF system with a test article bridging the two units. Figure 11 shows the test setup and the following table lists the physical size for the test article.

Table 3: Bridging Test Article Specifications

Bridging Test Article Specifications	
Length	163 inches
Width	40 inches
Height	31 inches
Weight	3,630 lbm
Length Center of Gravity	81.5 inches



Figure 11: Dual Cube Bridged Configuration

The test article contained an inner mass isolated on springs. The location and stiffness of these inner springs was unknown. The mass was nominally distributed between both Cubes and the bridging test article was secured to the top of the Cubes using standard cargo tie-down straps, four per Cube.

Figure 12 plots the results from all three axes for both Cubes. Considering again the vertical axis plot, reveals the most drastic improvements in the overall system performance. In these plots there are no

signs of control difficulty of the vertical axis for either Cube. This result indicates that even with nominally 1,800 lbm distributed to each Cube via the test article, the first natural frequency of the head expander structure remains above 500 Hz. This result highlights how much stiffness was added to the structure by integrating the head expander into the overall box structure of the Cube using lightweight webbing.

The longitudinal axis results remain within the tolerance limits of the test across the full bandwidth, with some deviation in control around 340 Hz where the profile makes a sharp change in levels. In addition, near 10 Hz the longitudinal control blooms up. This is most likely the result of a rigid body mode of the reaction mass or Cube isolation air springs, or possibly the inner test article resonating on its isolators.

Finally, considering the response of the transverse axis of both Cubes shows that there is some deviation from the control profile. Interestingly, Cube 1 performs better than Cube 2 between 250-400 Hz. Cube 2 has a peak in the response that exceeds the tolerance levels, but remains within the abort limits for three of the four measurement channels. One of the longitudinal measurements exceeds the upper abort level. In addition, both Cubes have difficulty controlling a rigid body mode near 12 Hz to the reference level. Similar to the single Cube results, the lowest level profile has the most deviation from the reference level. However, running the transverse axis profile alone allows for proper control of the dual Cube system. It is during the simultaneous excitation that the control of the transverse axis degrades due to its level relative to the others.

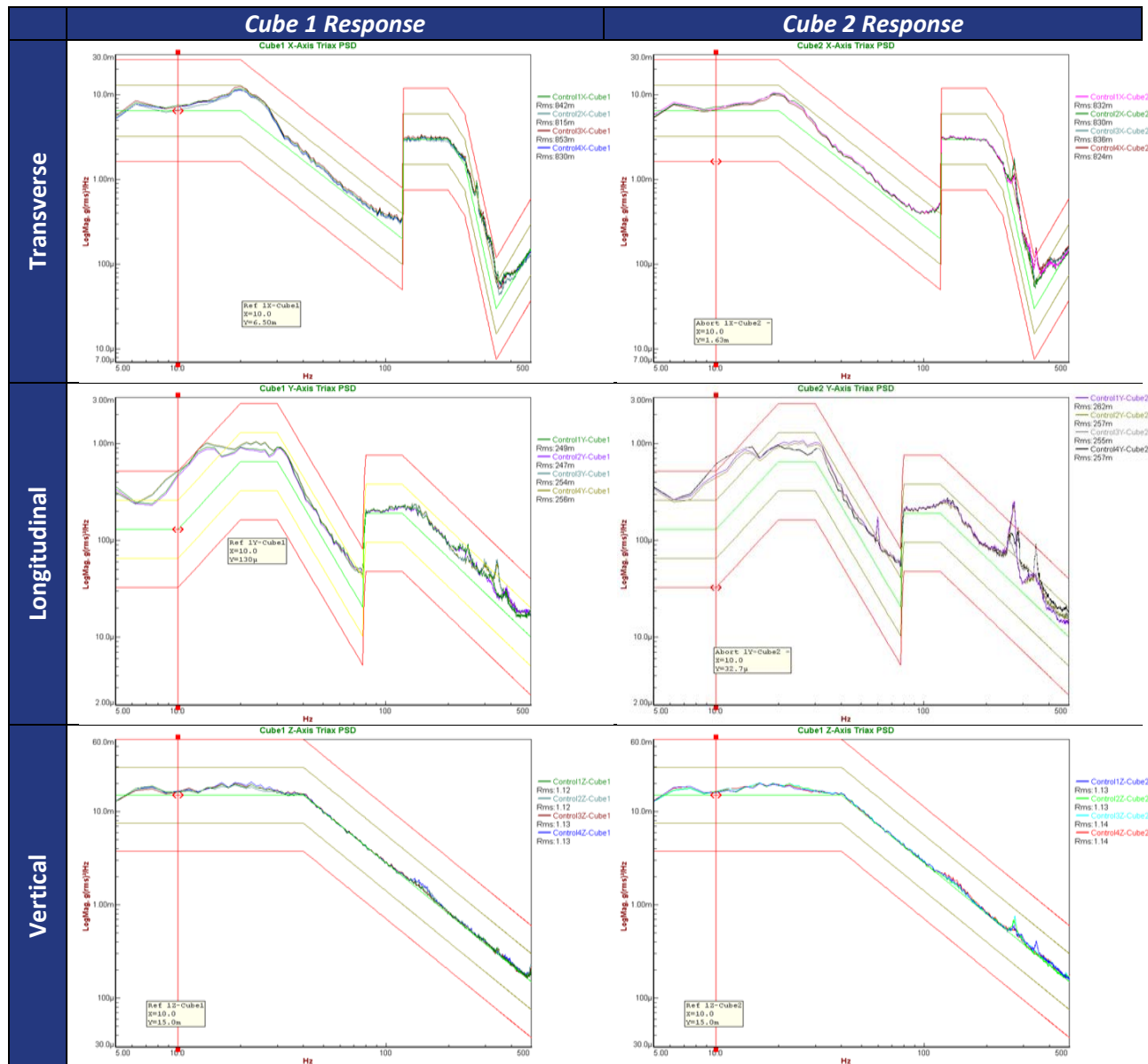

Figure 12: Dual Bridged Cube Longitudinal, Transverse, and Vertical Response

7 Conclusions

MIMO vibration testing of test articles, where all three axes are excited simultaneously, is a topic of increased interest and research within the vibration testing community. This testing approach allows the most realistic replication of a dynamic environment to properly excite a given test article. This paper described the design approach used by Team Corporation to develop a 6-DOF Cube vibration test system capable of simultaneously exciting a naval test article per the MIL-STD-810G Common Carrier Profiles.

In the case of the Cube system, to attain proper control of the test article the first natural frequency of the Cube structure must be above the bandwidth of the desired profile. Team developed a new structure that integrated the head expander structure into the overall design of the box, effectively increasing the loaded natural frequency above the 500 Hz bandwidth of the test. The details of the design were provided along with test results of the bare table structure. In addition, the results from operating a pair of Cubes to 500 Hz with a bridging test article are given. Both results show excellent improvements in the control of the z-axis profile, which was the profile most adversely affected by the structure's natural frequencies.

The paper touched on the differences between single axis vibration testing and simultaneous MIMO vibration testing. In simultaneous testing the control becomes increasingly difficult for DOFs whose profiles are significantly lower than the profiles of other DOFs. Often a system can properly perform a low-level test when done as a single axis test but has difficulties when running the same profile simultaneously with higher level tests on the adjacent axes. Issues such as system noise and cross-axis motion have a more pronounced effect in the simultaneous case with one low level profile. As the requirement for MIMO testing increases, addressing the issue of allowable error tolerances associated with the different profile levels in a given test will be important.

8 References

1. MIL-STD-810G Department of Defense Test Method Standard, Method 514.6 Vibration, Annex C. (31 October 2008). 514.6C-4.
2. Blevins, R. D. (1979). *Formulas for Natural Frequency and Mode Shape*. Malabar: Krieger Publishing Company.
3. MIL-STD-810G Department of Defense Test Method Standard, Method 527.1 Multi-Exciter Test, Annex C. (31 October 2008). 527C-1.