

# High Intensity Noise Generation for Extremely Large Reverberant Room Test Applications

Anant Grewal<sup>1</sup>, Ramani Ramakrishnan<sup>2,3</sup>, William O. Hughes<sup>4</sup>, Bill Woyski<sup>5</sup>, Gary Elfstrom<sup>3</sup>,  
Chon Mech<sup>5</sup> and Yong Chen<sup>1</sup>

<sup>1</sup> National Research Council Canada, Institute for Aerospace Research, 1200 Montreal Road, Ottawa, ON, Canada, K1A 0R6, email: anant.grewal@nrc-cnrc.gc.ca

<sup>2</sup> Department of Architectural Science, Ryerson University, 350 Victoria Street, Toronto, ON, Canada, M5B 2K3

<sup>3</sup> Aiolos Engineering Corporation, Suite 100, 2150 Islington Avenue, Toronto, ON, Canada, M9P 3V4

<sup>4</sup> NASA Glenn Research Center, 21000 Brookpark Road, Cleveland, OH 44135, USA

<sup>5</sup> Team Corporation, 11591 Watertank Road, Burlington, WA 98233-3626, USA

## ABSTRACT

A recent operational need for the development of a large (101,000 ft<sup>3</sup>) reverberant acoustic chamber at the Space Power Facility of NASA Glenn Research Center's Plum Brook Station with the requirement of generating sound pressure levels (SPL) as high as 163 dB has resulted in the need to re-examine the generation of noise in reverberant rooms. Early in the design stage, it was realized that the acoustic power level capability (10-30 kW) of conventional electrodynamic air modulators, such as those supplied by the Wyle Corporation, would be required in unprecedented numbers to meet the test spectra requirements. The design team then turned to a lesser known modulator, the hydraulically driven air modulator supplied by the Team Corporation, which has 150-200 kW acoustic power capability. The advantage to the project was a significant reduction in the number of modulators required to meet the requirements.

However, since only limited characterization of Team modulator's performance has been reported, a test program was required in order to mitigate the risk of the design of the RATF. Aiolos Corporation, which is responsible for the acoustic design of the RATF, and the Institute of Aerospace Research (IAR) of the National Research Council of Canada (NRC), entered into a collaborative agreement with the objective of characterizing, optimizing and investigating the controllability of the Team modulators. The test program was performed at the NRC-IAR reverberant chamber, a 19,000 ft<sup>3</sup> facility located in Ottawa, Ontario, Canada. The current paper provides details of the principle of operation of the Team modulators, including their servo control loops and provides of a summary of the characterization and controllability test program.

## 1.0 INTRODUCTION

The NASA Space Environmental Test (SET) Project is tasked to develop new environmental test facilities to support NASA's developing space exploration program. The Space Power Facility (SPF) at the NASA Glenn Research Center's Plum Brook Station in Sandusky, Ohio, USA is already the home of the world's largest thermal vacuum chamber. In order to provide the aerospace customer with one-stop testing for the suite of space environmental testing, the SPF is being augmented through the NASA SET Project Office with new reverberant acoustic [1], mechanical vibration [2], and modal test [2] facilities.

In August 2007, Benham Companies, LLC (Benham), located in Oklahoma City, Oklahoma, USA, won the NASA prime contract to design and construct the acoustic, vibration and modal test facilities, as well as to provide the high speed data acquisition system to support these facilities. Benham contracted with Aiolos Engineering Corporation (Aiolos), located in Toronto, Ontario, Canada to provide the acoustic design of the Reverberant Acoustic Test Facility (RATF).

The RATF will be a unique acoustic test facility due to its combination of very large chamber test volume and extremely high acoustic sound levels. Typically, the world's larger reverberant test chambers have a volume of ~ 50,000 to 76,000 ft<sup>3</sup>, and can produce an empty chamber overall sound pressure level (OASPL) of approximately 152 to 157 dB. However the RATF has a volume of approximately 101,000 ft<sup>3</sup> and has been designed to produce an empty chamber test level of 163 dB OASPL. Amongst the world's active known reverberant acoustic chambers only the Lockheed Martin test facility located in

Sunnyvale, California, USA is larger in volume at 189,200 ft<sup>3</sup> than RATF, but that test facility produces an empty chamber level of approximately 156.5 dB OASPL, which is at least 6 dB less than RATF’s predicted capability. The RATF’s combination of size and acoustic power was necessary to meet NASA’s requirements to test the next generation of large space exploration vehicles whose acoustic environments have been predicted to be 163 dB OASPL or even higher.

## 2.0 RATF REQUIREMENTS

The key requirements for the RATF acoustic design were as follows:

- a. The RATF shall be physically as large as possible within the given space limitations of SPF.
- b. The RATF’s test chamber shall be properly sized to acoustically test four space vehicle configurations, encompassing an 18-ft diameter test article, and a 47-ft tall test article.
- c. The RATF’s test chamber shall physically allow a 32.8-ft diameter test article weighing up to 120,000 pounds.
- d. The RATF shall generate the empty chamber acoustic test spectra shown in Figure 1, for continuous test duration of 10 minutes. These eight (8) “C” spectra represent a wide range of current and future NASA missions, including five (5) spectra with a 163 dB OASPL.
- e. The RATF shall include an independent, multi-channel digital acoustic control system capable of controlling the noise sources to the sound pressure levels (SPL) and spectra shown in Figure 1, within specified tolerances (+5dB below the 50 Hz one-third octave bands (OTOB), +3dB covering 50 Hz-2K Hz OTOB’s, +5dB above 2K Hz OTOB’s, +1.5dB on OASPL).

The physical size of the RATF was determined from the maximum available space within the SPF, along with following guidelines on proper room ratios and good acoustic test practices. Benham and Aiolos ultimately designed a reverberant acoustic test chamber with the following dimensions: 47.5-ft long x 37.5-ft wide x 57-ft high. After accounting for the main chamber door jamb structure the resulting chamber volume is 101,189 ft<sup>3</sup>. A picture of the RATF under construction is shown in Figure 2.

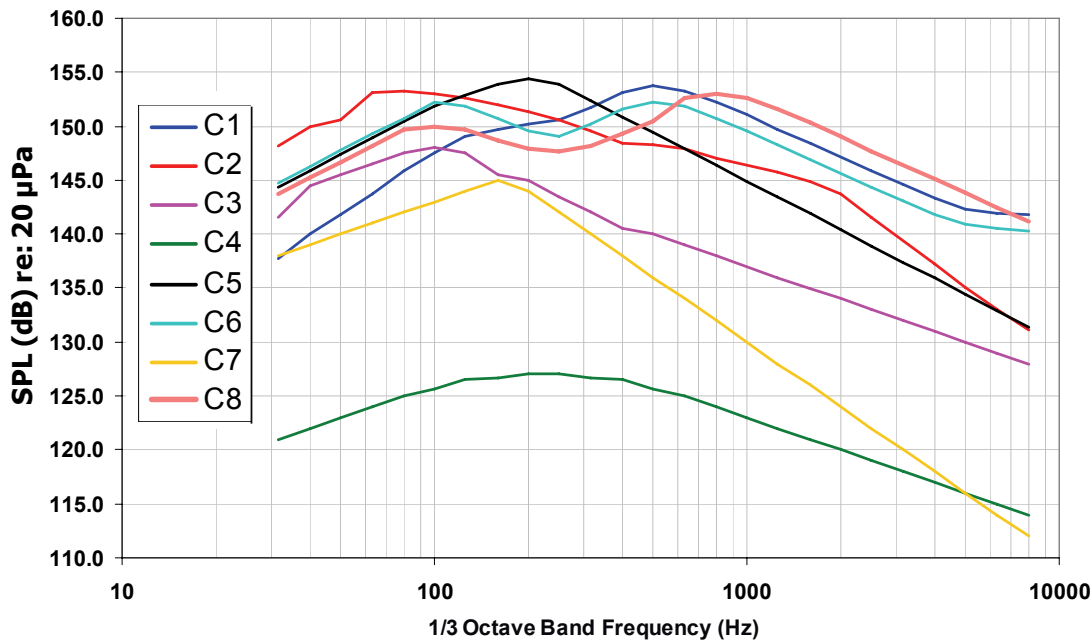

**Figure 1: Acoustic Test Spectra Requirements**

The next design issue was to determine the number and type of acoustic modulators or noise generators that would be needed to create the enormous sound power necessary to sustain the high SPL in this large chamber volume. Prior to the “C” acoustic spectra requirements becoming effective in September 2008, six other spectra were originally required including three spectra whose characteristics and SPL were very similar to the C2 spectrum, as shown in Figure 1. The common characteristic of the initial three spectra and C2 is very high SPL at frequencies at and below 100 Hz. The Wyle WAS3000 modulator, which has been in use since the 1960’s, with an acoustic power generation capability of 30kW, was initially considered. Preliminary analysis showed that over fifty WAS3000 would be required to meet the initial three spectra. Most of these modulators would be paired with low frequency horns, which have very large dimensions at the horn mouth, the end result being a multitude of design problems in terms of integration with the chamber structure.



**Figure 2: Ongoing Construction of the NASA Reverberant Acoustic Test Facility (RATF). The modulators are located behind the horn wall shown in the photograph.**

The need was clear to reduce the number of horns by selecting higher power modulators. The only known commercially available high acoustic power modulators were the Team Corporation (Team) modulators with models known as the MK-VI and MK-VII. The Team modulators, although not widely utilized within the reverberant acoustic industry, are especially effective at the low frequencies (at or below the 125 Hz OTOB) with a rated modulator acoustic power of 150 kW (kilowatts) and 200 kW, respectively. These Team modulators were eventually paired with horns with six different cut-off frequencies (25, 35, 50, 80, 100 and 160 Hz) for the final RATF design. Benham later augmented the RATF design with several Wyle WAS-5000 modulators on 250 Hz horns to add to the high frequency capability of the RATF.

Although the Team modulators have been in service for over 40 years, there was not much acoustic characterization data available on them. To obtain Team modulator characterization data, and to qualify and mitigate any associated risk to NASA, Aiolos jointly with staff at the National Research Council of Canada (NRC) designed and conducted a series of test programs [3] at the Ottawa NRC 19,000 ft<sup>3</sup> reverberant acoustic test facility.

### **3.0 TEAM AIR MODULATOR**

#### **3.1 History**

Team Corporation has been involved with the design, manufacture, application and installation of Air Modulators for more than 40 years. The Air Modulator is the evolutionary development of an acoustic generator designed in the early 1960s by Don Skilling at the Aircraft Division of Northrop Corporation. Skilling's early work focused on the use of electro-dynamic shakers as the motive force for opening and closing the poppet valve. It then became apparent to him that the superior force to mass ratio of the hydraulic shaker might open and close the air valve to even higher frequencies. He demonstrated that the use of hydraulic shakers did indeed extend the controllable acoustic spectrum out beyond 500 Hz.

Team Corporation worked with Northrop as a supplier and subcontractor from the initial design until Team purchased the product line in 1983. At Team, the MK-V model was dropped and the power of the MK-VI was increased from 85 kW (acoustic) to the current 150 kW (acoustic). The MK-VII Air Modulator was not altered significantly from the original design. Both the MK-VI and MK-VII benefited from Team's servo valve and servo controller improvements. The

improvements eliminated the instabilities that the very early Northrop Air Modulators exhibited, with the result that current models are repeatable and reliable.

### 3.2 Modulator Design

Figure 3 displays the complete Air Modulator assembly. The Air Modulator comprises the hydraulic actuator, poppet valve and seat, and an air supply plenum. The poppet valve is housed in an air plenum designed to deliver a steady uniform source of air to the poppet valve. The plenum mounts to the throat of the acoustic horn. An air supply line is also connected to the plenum. The Air Modulator is designed to operate at air supply pressures between 40 and 200 psig.

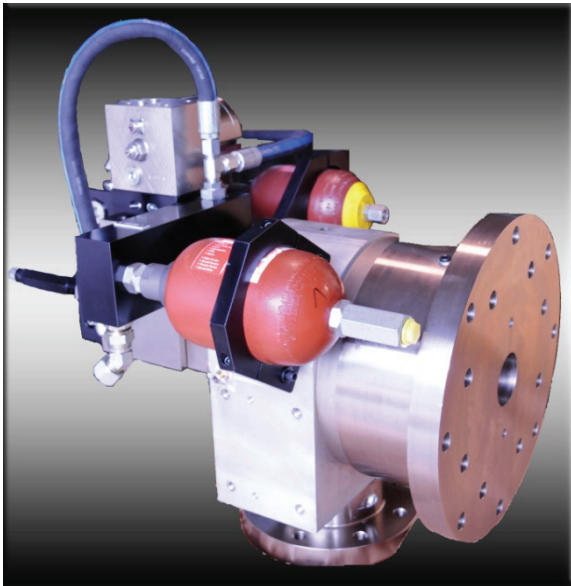

Figure 3: Team Air Modulator

The actuator is mounted on the plenum in such a way that it can drive the poppet valve via a short concentric shaft. The air valve is a reciprocating poppet valve that is driven by a special high response electro-hydraulic actuator (see Figure 4). The hydraulic actuator is driven by Team servo valves models V-20 and V-140. The V-20 valve, called the pilot valve, is a voice coil driven, four way spool valve. The V-140 valve, called the slave valve, is driven by the pilot valve and provides high flow to the actuator.

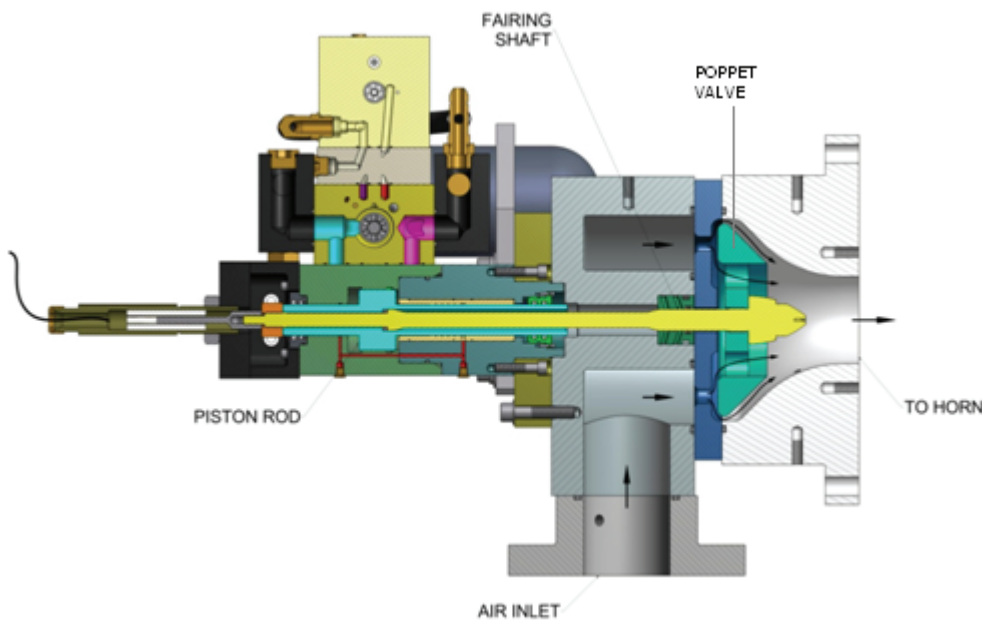

Figure 4: Acoustic Modulator Assembly cutaway with air flow paths.

The command signal can be generated by an automatic control system or a manual random noise shaping system. The voice coil signal is generated from the command with a position servo loop and a power amplifier. The poppet valve position is monitored, and fed back and serves as the control parameter.

The hydraulic actuator features hydrostatic bearings that prevent metal to metal contact and it uses no high pressure seals. This reduces the wear on parts and increases the longevity of the actuator. Additionally, the high frequency response dual stage voice coil driven servo valve allow air modulation out to high frequencies. The frequency response of the Team air modulators is shown in Figure 5.

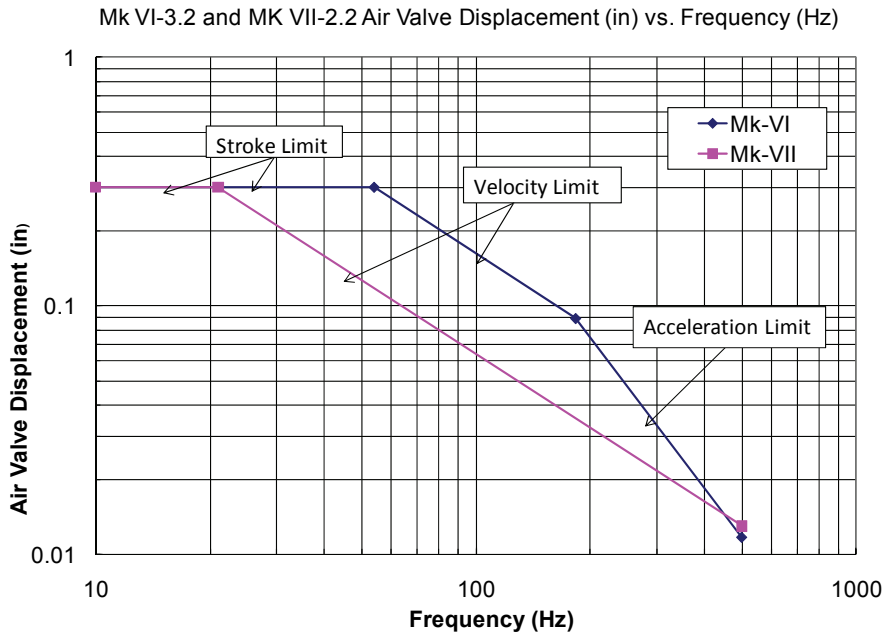

Figure 5: Team MK-VI and MK-VII Air Valve Displacement versus Frequency

### 3.3 Principle of Operation

#### 3.3.1 Air Modulator

The Air Modulator system is developed specifically to generate broad band random noise. The main emphasis during the development was to maximize the efficiency and power output while keeping the mechanism simple and reliable. The acoustic power is given by the following equation [4]:

$$W_a = 0.166 \times Q \times E_a [(P_R)^{0.288} - 1]$$

Where  $W_a$  is the acoustic power in kilowatts;  $Q$  is the air flow in SCFM (standard ft<sup>3</sup> per minute);  $E_a$  is the air stream to acoustic power efficiency; 0.166 is a factor for units at standard condition; and  $P_R$  is the pressure ratio (i.e. the ratio of supply pressure to outlet pressure). The air modulator theoretical efficiency of air stream power to acoustic power is approximately 33%. The Team MK-VI and VII modulators can operate with either air or gaseous nitrogen as their pressurized gas source. The RATF will use gaseous nitrogen for its operation, whereas air was used for all testing at the NRC.

#### 3.3.2 Air Modulation by Poppet Valve

High energy noise is produced by modulating the flow of a large quantity of high pressure gas with a mechanically driven poppet valve. The Team modulator differs from other air modulators in that it closes off the air stream completely when the poppet valve is shut and, if the supply pressure is high enough, generates a shock wave in the air stream when it opens. This creates the large pressure fluctuations required to produce 160 to 175 dB sound pressure levels in the test cell. The shock waves produce a broadband acoustic spectrum in the acoustic test cell, which can be a reverberant chamber or progressive wave tube.

During random operation, the Air Modulator normally produces a broad band random spectrum that is both smooth and continuous. The spectrum shaping is done in the traditional manner of shaping the input command spectrum up to about 500

Hz, after which the actuator can no longer produce sufficient displacement to modulate the open area of the poppet valve. The spectrum is also influenced to lesser extent by the air pressure, and force with which the poppet valve is held against its seat. The force needed to hold the poppet valve against the seat increases with increasing supply pressure, and this is accounted for with a servo bias applied toward the closed direction. A library of input settings and the resulting acoustic levels is accumulated to assist the operator in attaining a given test condition. The Air Modulator will repeat a given output if all the input parameters are duplicated.

### 3.3.3 MK-VI and MK-VII Specifications

The performance specifications for the MK-VI and MK-VII modulators are summarized in Table 1.

**Table 1: Performance Specification of the Team MK-VI and MK-VII Modulators.**

Parameter	MK-VI 3.2	MK-VII 2.2
Acoustic power output at rated hydraulic power supply of 30 gpm at 3000 psig	150 kW @ 2900 SCFM and 150 psig	200 kW @3800 SCFM and 150 psig
Poppet valve frequency response	20 to 500 Hz	20 to 500 Hz
Frequency Content of Acoustic Output	To 10 kHz	To 10 kHz
Servo valve flow capacity	140 LPM at 200 Hz	140 LPM at 200 Hz
Minimum hydraulic power supply	30 gpm at 3000 psig	30 gpm at 3000 psig
Recommended gas flow range	1500 to 3500 SCFM	1500 to 4500 SCFM
Recommended gas pressure range	120 to 200 psig	120 to 200 psig

## 4.0 MODULATOR TEST PROGRAM

The achievable performance such as, power output, spectral shape and amplitude control, for the Team modulators was determined by conducting a series of test programs at the reverberant test chamber at NRC-IAR in Ottawa, Ontario.

The aim of the test programs was to establish the behavior of the Team modulators with different parameters such as modulator gas supply pressure, the character of the broadband random input signal (including the dc bias of the servo-amplifier and the spectral shape), and the pressure of the hydraulic fluid.

The main acoustic parameters of interest were:

- The sound pressure level inside the reverberant chamber (both overall level and spectra);
- The acoustic power of the modulators at the horn mouth and at the modulator outlet; and
- The spatial variation of the sound inside the chamber.

The details of the test program are presented in this section.

### 4.1 Test Objectives

The acoustic test objectives can be summarized as follows:

- Determine the quantitative relationship of bias to modulator efficiency, flow, and acoustic output levels with the various horns;
- Demonstrate the repeatability of the modulator's acoustic performance;
- Demonstrate the controllability of the modulator to generate different spectral shapes by varying pressure, bias, input signal gain, and input signal spectrum; and
- Demonstrate the controllability of the modulator to generate consistent spectral shape output at full level and -6 dB settings.

#### 4.1.1 Dynamic Range

The dynamic range of the modulator was determined as the signal within the test chamber was incremented slowly to the maximum desired specification. Ideally, the dynamic range should be at least -12 dB, with the desire to explore the range between -12 dB and -18 dB. Hence testing was performed with the modulator, whose powers were reduced from 0 to -18 dB in 3 dB increments.

### 4.1.2 Closed Loop Modulator Testing

The test objectives of Controlled Loop Modulator Testing were:

- Demonstrate that a Team modulator can be adequately controlled via acoustic feedback in a manner similar to other acoustic sound generators.
- Characterize the performance metrics of the Team modulators under closed loop control.
- Provide useful data for later inclusion in a performance specification for competitive bidding of an Acoustic Control System.

Acoustic closed loop testing was initially performed with a single MK-VII Team modulator coupled to the 25 Hz horn and then a single MK-VI Team modulator coupled to the 160 Hz horn in the NRC-IAR Reverberant Test Facility. The in-house NRC-IAR Acoustic Control System was employed with a total of 6 control microphones. For each target spectrum, the optimum bias was applied. The pneumatic pressure was within the range 150 to 175 psig. The closed-loop performance was characterized in terms of response time for each 1/3-octave band (25 Hz to 500 Hz) as well as the steady state error.

### 4.2 Modulator Hydraulic and Pneumatic Supply

For the characterization tests at the NRC, the hydraulic supply for a single modulator was provided by a MTS 30 gpm pump that was capable of supplying 3000 psig. When dual modulators were tested, a MTS pump rated at 70 gpm at 3000 psig was employed.

The air supply for the Team modulators is provided by a 8 MW compressor plant that fills three storage tanks with a total capacity of 50,000 ft<sup>3</sup> to a pressure of 300 psig. Note that this system is capable of filling the tanks to the aforementioned pressure in approximately 30 minutes. The air supply to the modulator was regulated using a 6" valve and delivered using 6" diameter piping. A 240 gallon accumulator was also placed in-line between the valve and modulator to reduce the pressure fluctuations within the pneumatic supply system. A schematic diagram of the air delivery system is shown in Figure 6.

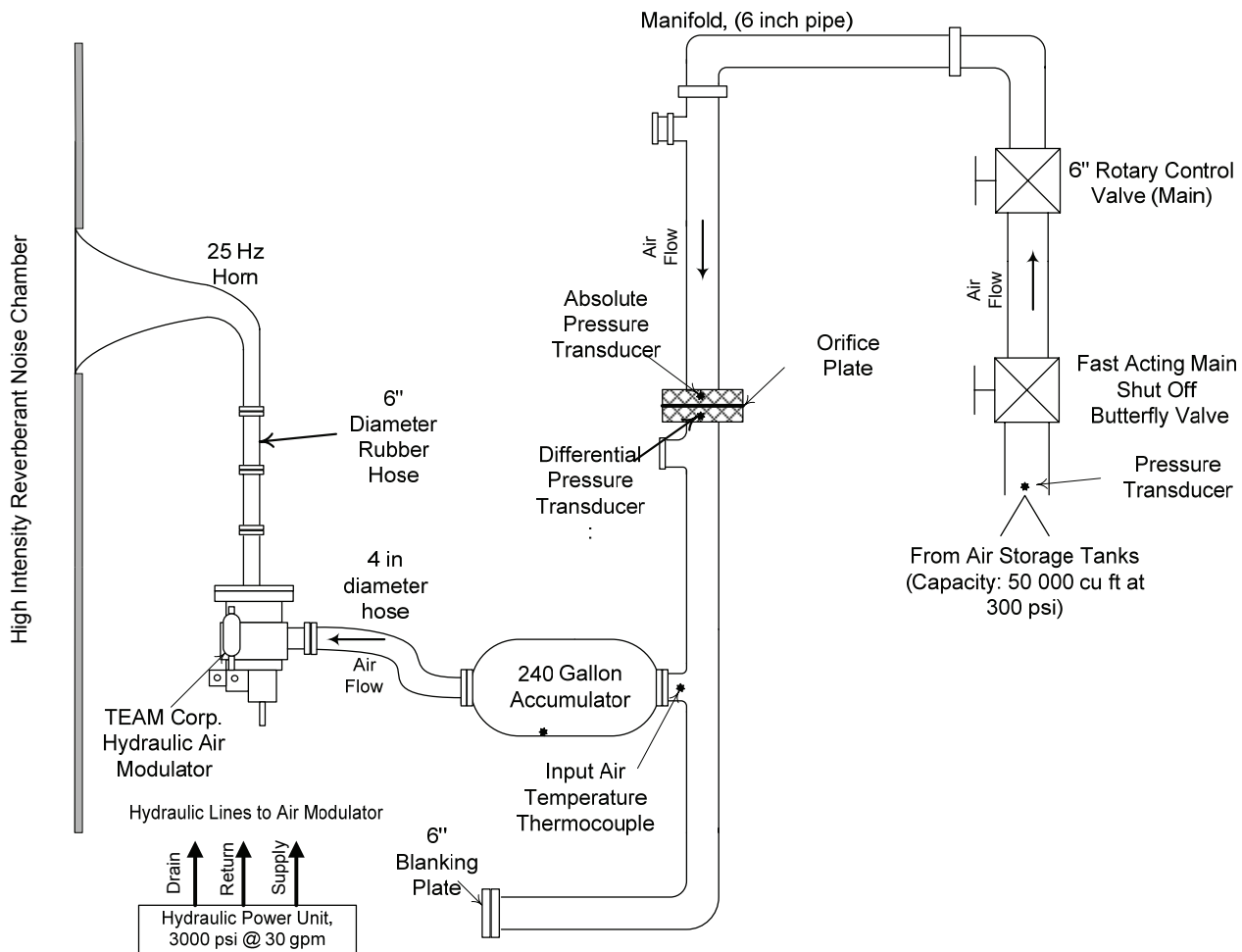

Figure 6: Schematic of Air Delivery System used in Modulator Testing.

### 4.3 Data Acquisition Systems

There were two types of data collected namely acoustic and pneumatic/hydraulic data. The acoustic measurements were used to establish the sound power emitted from the modulators, while the principal use of the pneumatic data was to determine process parameters such as temperature, pressure and mass-flow, which were used to determine the efficiency of the modulators. The hydraulic data was mainly used in a monitoring capacity.

As expected, the sampling rate requirement for the two types of data were very disparate; the acoustic data was sampled at 25.6 k-samples/sec, while the process data was sampled at 100 samples/sec. The acoustic data was collected and processed using an LMS Test.Lab system, while a National Instruments/Labview system was used to collect and process the raw pneumatic measurements.

### 4.4 Acoustic Measurements

Each of the modulators with its support system and horn adapter was installed inside the horn/modulator room of the NRC test chamber in Ottawa, Ontario. A photograph showing the Team MK-VI modulator during testing at the NRC is shown in Figure 7. The supply gas was dry air at 20°C and was connected to the two modulators through a single T-junction connection. One of the modulators was connected to the 25 Hz horn and the other was connected to either a 100 Hz or 160 Hz horn. Tests were performed with each modulator operating alone on each of the two horns and also with both modulators operating at the same time. The gas pressure to each modulator was the same when two modulators were operating together.

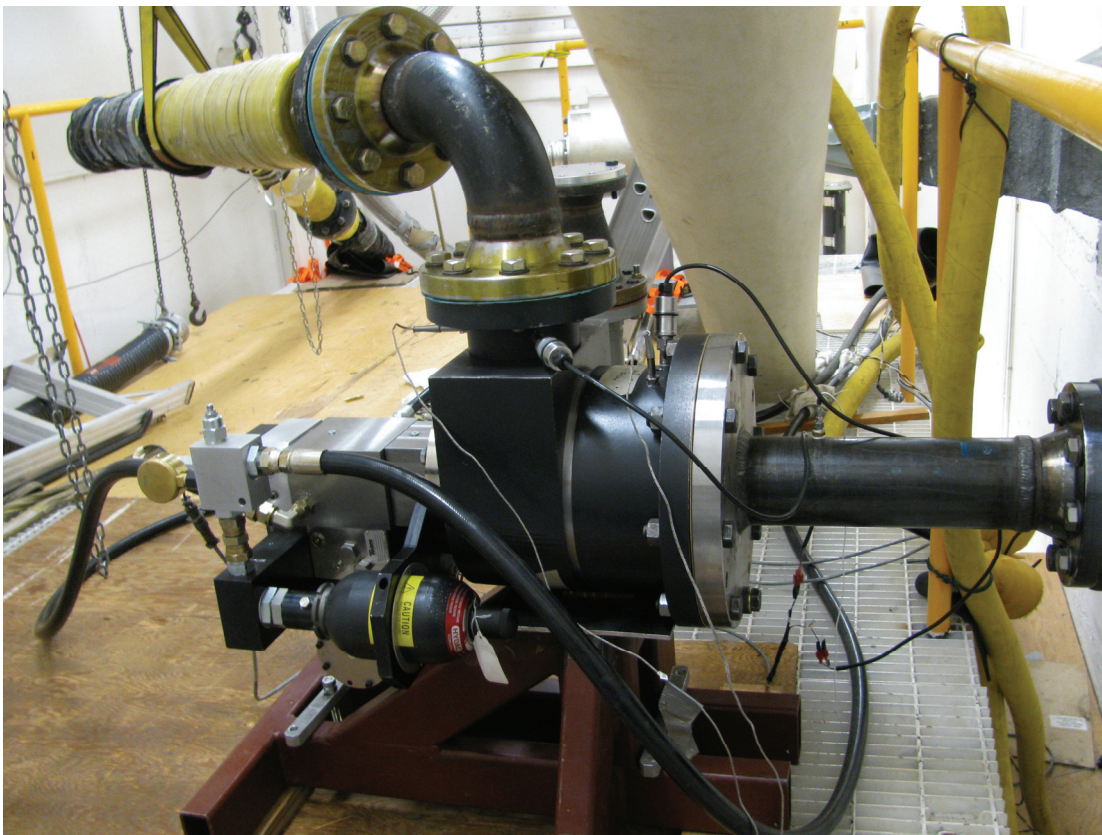

**Figure 7: Team MK-VI Modulator during Testing at NRC.**

The test process was as follows: the modulator was energized at a single pressure and a broad-band noise signal, set at a particular dc bias and shaped in 1/3 octave bands, was commanded to the servo-amplifier of the modulator to control the modulator valve. The resulting sound pressure level was measured inside the chamber using a minimum of six free field microphones. Time averaged (about 30 seconds) 1/3-octave band spectra were recorded from each of the microphones. The test at the set gas pressure was repeated with several modified 1/3-octave band noise signal inputs to the servo-amplifier. Tests were also performed with a different dc-bias value. The influence of the hydraulic fluid pressure was also evaluated for a few test conditions.

The above test was repeated for six pre-set gas pressures. This test procedure was repeated for a number of different modulator-horn combinations including: MK-VI on a 25 Hz horn, MK-VI on a 100 Hz horn, MK-VII on a 25 Hz horn, and MK-VII on a 100 Hz horn; both single and dual modulator operations were tested.

In addition, the chamber reverberation time was also measured in 1/3 octave bands from 50 Hz to 10,000 Hz and the relative humidity was kept below 5% for the reverberation time tests. The following parameters were recorded for each test condition:

- 1/3-octave band sound pressure levels from each microphone in the test chamber
- 1/3-octave band sound pressure levels from a microphone placed in the horn room
- Test chamber pressure
- Test chamber temperature
- Chamber air humidity

#### 4.5 Process Measurements

The following quantities also were also measured in order to allow for a complete characterization of the modulator performance:

- Modulator inlet and outlet air pressure
- Modulator inlet and outlet air temperature
- Modulator hydraulic supply and return pressure
- Modulator air mass flow

An orifice plate was installed in the manifold to allow for mass flow measurement during testing. The mass flow,  $\dot{m}$ , and volume flow (in Standard ft<sup>3</sup> per Minute, SCFM),  $Q_{SCFM}$ , are obtained from the orifice plate inlet pressure,  $P_s$ , differential pressure across the plate,  $\Delta P_j$ , and the air temperature,  $T$ , as follows:

$$\dot{m} = CA_o \sqrt{\frac{2\Delta P_j P_s}{RT}}$$

$$Q_{SCFM} = \frac{CA_o}{P_{atm}} \sqrt{2RT\Delta P_j P_s}$$

$R$ , is the gas constant for air,  $P_{atm}$ , is the atmospheric pressure,  $A_o$ , is the orifice area, and  $C$  is the discharge coefficient of the orifice plate, which is equal to 0.615. The mass flow computation allows for the evaluation of the air stream to acoustic power efficiency.

#### 4.6 Acoustic Control System

The noise input to the NRC reverberant chamber is controlled using a proprietary acoustic control system, initially developed by NRC in the 1990's. The current implementation of the control system uses a high performance National Instruments (NI) PXI Embedded Real Time Controller for deterministic real-time operation. The system consists of a NI PXI-1042 chassis equipped with a PXI-8106 embedded controller and three PXI-4461 I/O modules, each of which has a pair of analog input and output channels with 24-bits A/D and D/A convertors. The control algorithm executes on the real time controller (running a real-time operating system, RTOS), while program I/O executes on a regular Windows-based PC. Communications between both computers occurs via an Ethernet connection.

The control target is specified in terms of 1/3-octave band levels from 25 Hz to 2000 Hz. A Gaussian white noise signal is filtered by a bank of 1/3-octave filters whose attenuation values are controlled by individual feedback control loops. The 1/3-octave filters are implemented in the digital domain using 10<sup>th</sup> order IIR filters that are ANSI and IEC compliant.

### 5.0 MODULATOR TEST RESULTS

The present section provides details of the experimental results collected during the test program. These include the modulator characterization tests as well as the closed loop tests.

#### 5.1 Performance Characterization Test Results

In addition to measuring the acoustic output power as a function of various parameters, other aspects of the modulator behavior, including dynamic range, repeatability, and the effect of signal spectral properties were also evaluated.

##### 5.1.1 Acoustic Power Output

The total modulator acoustic power was calculated from the averaged chamber sound pressure levels, the measured chamber reverberation time values and the various adjustment factors that are described below. The acoustic power level at the horn mouth, denoted as  $PWL_1$  is given by the following equation:

$$PWL_1 = SPL + 10 \log(S\alpha + 4\beta V)$$

where  $SPL$  is the averaged chamber sound pressure levels,  $S$  is total surface area including adjustments for vents and horns;  $\alpha$  is the wall absorption coefficient, computed from the chamber reverberation time values,  $V$  is chamber volume and  $\beta$  is the air absorption coefficient of the chamber. The acoustic power level of the modulator, denoted as  $PWL_2$  is related to  $PWL_1$  by the following relationship:

$$PWL_2 = PWL_1 + 10\log(\epsilon) + \text{Wall corner effects} + \text{Spill over} + \text{Horn Efficiency}$$

where  $\epsilon$  is the coupling efficiency, defined as  $\epsilon = M/(M + 1)$ , where  $M$  is the Modal overlap Index, with  $M = \eta\Delta$ .  $\eta$  is the Modal density and  $\Delta$  is the half power-pass band. The correction for wall corner effects is given by [5]:

$$\text{Wall Corner Effects} = 10 \log(1 + Sc/8fV)$$

The spill-over loss is assumed to be 0.2 dB, based on typical values. The horn efficiency is assumed to be 30% for a typical exponential horn (the efficiency is usually between 30 and 35%). The acoustic powers of the modulator for typical test runs are shown in Table 2 below.

**Table 2: The Sound Power Output of Team Modulators**

Modulator Type	Test Run No	Modulator PWL, dB re $10^{-12}$ watts	Modulator Power, kW
MK-VI	#7	169	77
MK-VI	#8	172	150
MK-VII	#9	173	200
MK-VII	#18	172	152

The results of Table 2 clearly shows that the Team modulators are capable of producing 150 kW (MK-VI modulator) and 200 kW (MK-VII modulator) as advertised. Note that cases that yielded less than the maximum modulator power corresponded to non-optimal servo bias, input spectra and/or gas supply pressure settings.

### 5.1.2 MK-VI Modulator General Behavior

For the tests described in this section, the MK-VI modulator was coupled to a 100 Hz horn. The MK-VI is designed to have improved higher frequency performance, which inherently sacrifices its low frequency behavior.

A number of different input signals were applied to the modulator:

- a) A flat white noise spectrum from 80 Hz to 800 Hz;
- b) Several spectra obtained by shaping the flat 80 Hz to 800 Hz spectrum;
- c) Individual 1/3-octave band or octave band signals.

The key acoustic results obtained for the MK-VI modulator are presented in Figure 8. The effect of modulator output with supply pressure is shown in Figure 8 (a). Between 125 and 225 psig, the supply pressure has a negligible effect on the acoustic output of the modulator. Note that for the cases in Figure 8(a), the shape of the input spectra was white noise between 80 Hz and 800 Hz. The effect of the spectral shapes of the input signal is shown in Figure 8 (b). The results show that the shaping of the input signal is reflected in the shape of the output spectra, indicating a high degree of spectral controllability. These results also illustrate the affect of the 100 Hz horn characteristics on the output for a flat white noise spectrum.

The effects of applying input noise exclusively within a single 1/3-octave band are shown in Figure 8 (c) and (d), where noise is contained only within the 100 Hz and 250 Hz bands, respectively. In each case, two signal gain values, as indicated in the figure legends, are applied. These results suggest that the desired modulator output spectra and levels can be readily obtained by adjusting the input spectra shape and levels. This again demonstrates that the modulator exhibits good controllability characteristics. This aspect will be examined in greater detail later in this paper. The repeatability of the Team MK-VI modulator was evaluated simply by repeating measurements with identical input spectra, gas supply pressure and the servo bias settings. In many cases, the repeated measurements were conducted on different days. In all cases the repeatability was excellent. Figure 8 (e) and (f) shows two such cases.

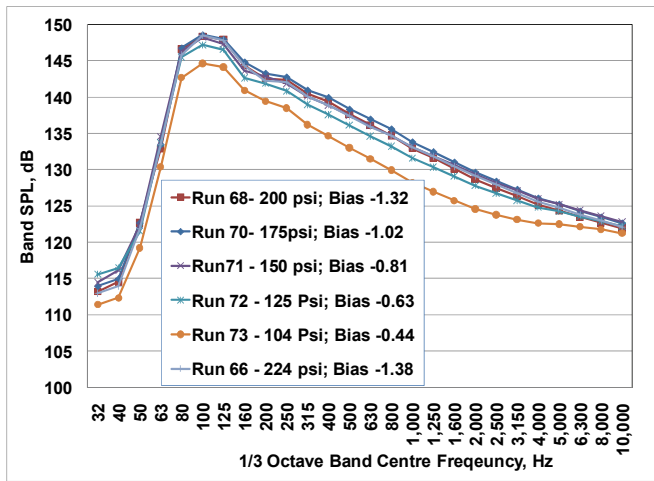

(a) Effect of Supply Pressure

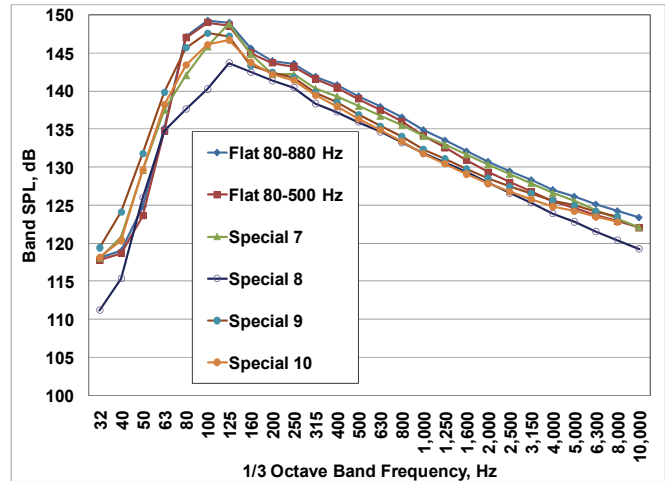

(b) Effect of Signal Shape

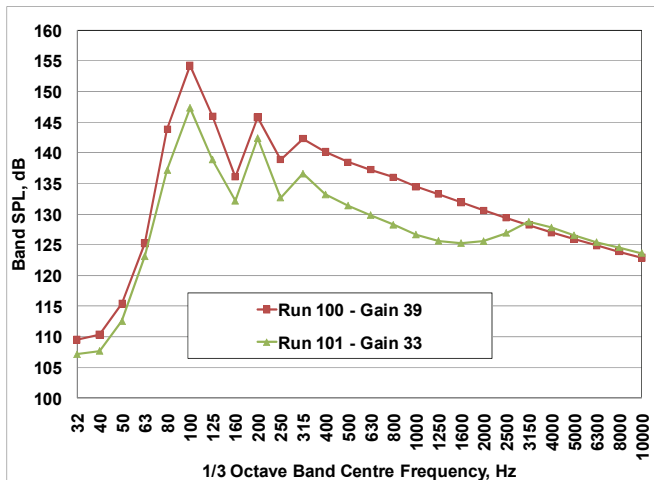

(c) Effect of Signal Gain and Signal Shaping, case 1

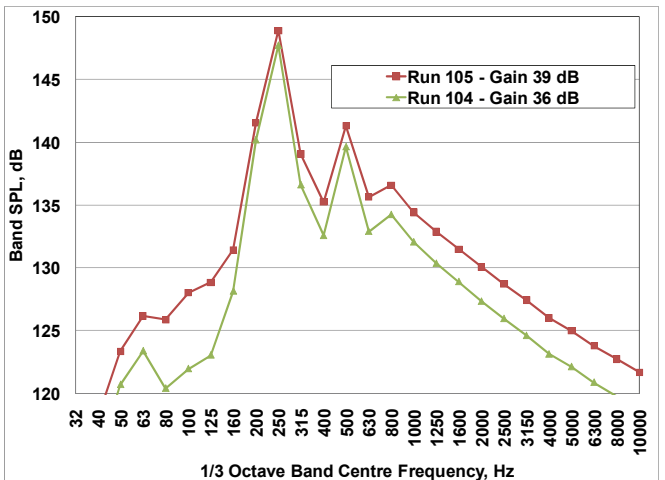

(d) Effect of Signal Gain and Signal Shaping, case 2

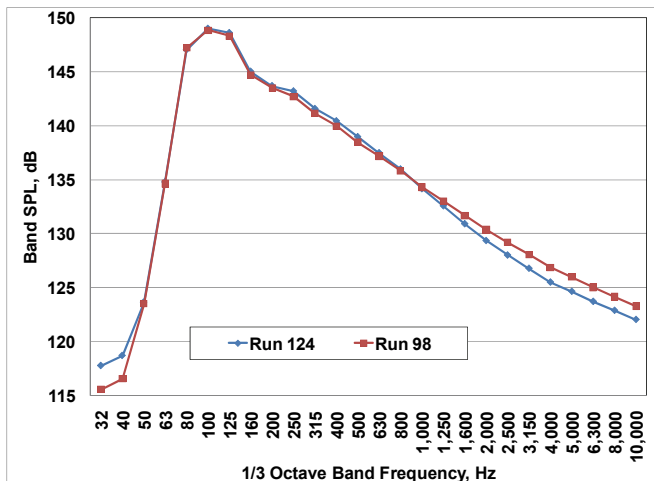

(e) Repeatability Test, trial 1

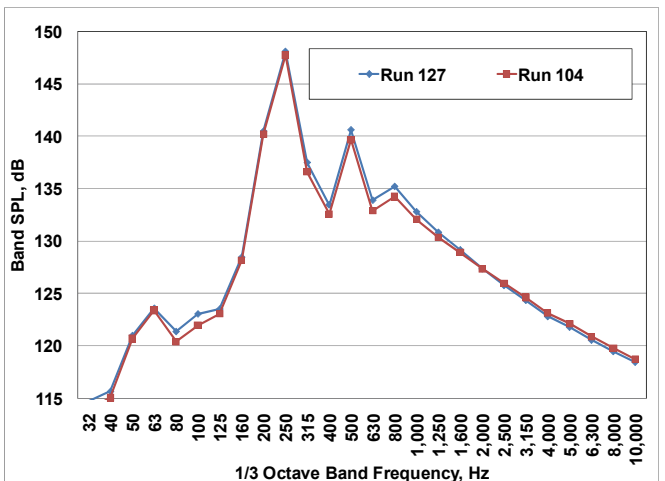

(f) Repeatability Test, trial 2

**Figure 8: The behavior of MK-VI Modulator.**

### 5.1.3 MK-VII Modulator General Behaviour

With the MK-VII modulator coupled to a 25 Hz horn, a few different combinations of the input signal were also applied:

- a) A flat spectrum from 25 Hz to 800 Hz;
- b) Several spectra obtained by shaping the flat 25 Hz to 800 Hz spectrum;
- c) Individual 1/3-octave band or octave band signals.

Compared to the MK-VI, the MK-VII was typically tested with input signals that had greater energy content in the low frequency range to exploit its frequency response range. The effect of supply pressure on the performance is shown in Figure 9 (a). These results show that at and above a supply pressure of approximately 115 psig, the acoustic output of the MK-VII modulator is essentially invariant with pressure. The case shown with a low acoustic output is the result of an extremely low supply pressure, well below the rated minimum supply pressure of 120 psig. The variation of the output power spectrum with input signal spectrum is shown in Figure 9(b). In particular the additional energy content in the bands from 100 to 800 Hz is clearly visible when the corner frequency of the input signal is increased from 100 Hz to 800 Hz. Spectra 2 and 4 attenuate the baseline input spectrum (flat to 800 Hz) beyond 100 and 400 Hz by 3 dB per octave, and the effects are seen accordingly in the output spectra.

The combined effect of signal gain and narrowband performance is shown in Figure 9 (c) and (d). In the former case, input energy is only contained within the 50 Hz 1/3-octave band. Apart from some spill-over in the 100 Hz band, the output power is concentrated within the 50 Hz band. Furthermore, the effect of the input gain appears at the output in a linear fashion. The same can be said when the energy is contained within the 200 Hz 1/3-octave band, as shown in Figure 9 (d). The repeatability of the MK-VII is exemplified by the results shown in Figure 9 (e) and (f) for two representative cases.

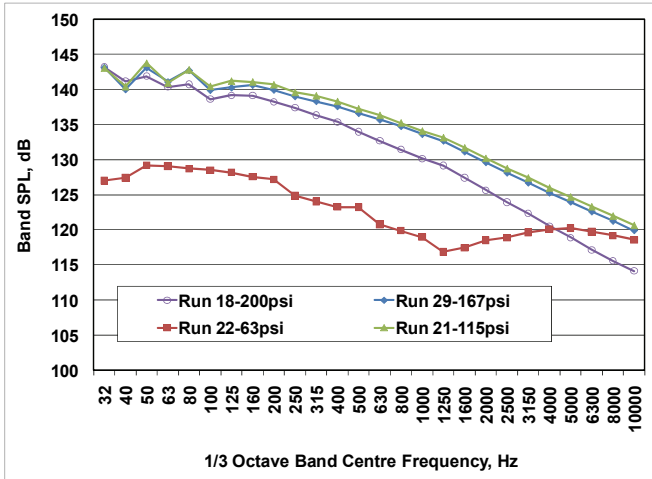

(a) Effect of Supply Pressure

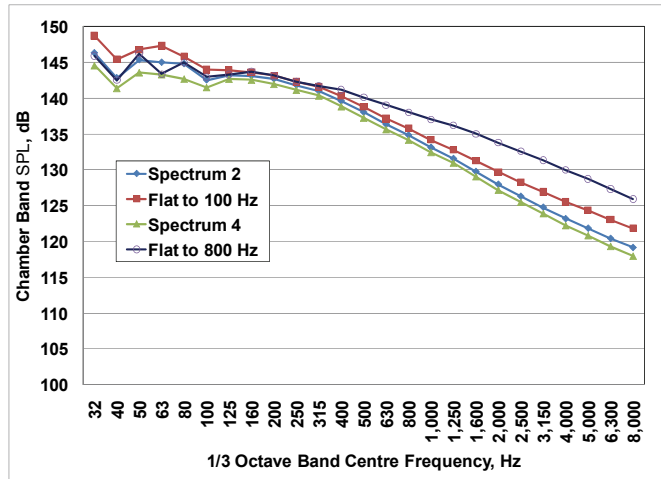

(b) Effect of Signal Shape

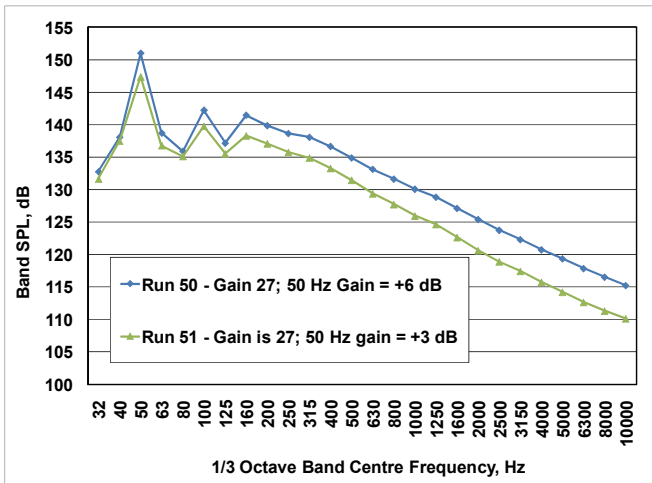

(c) Effect of Signal Gain and Signal Shaping, case 1

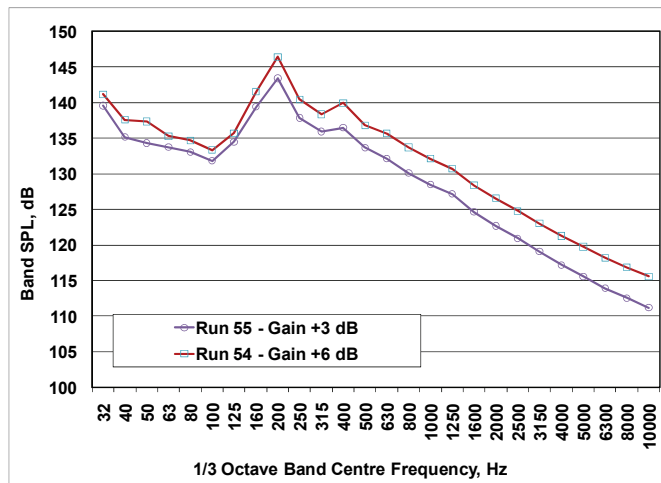

(d) Effect of Signal Gain and Signal Shaping, case 2

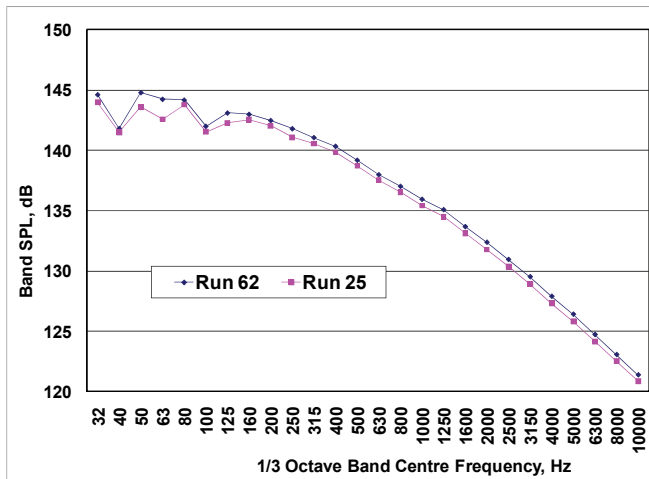

(e) Repeatability Test, trial 1

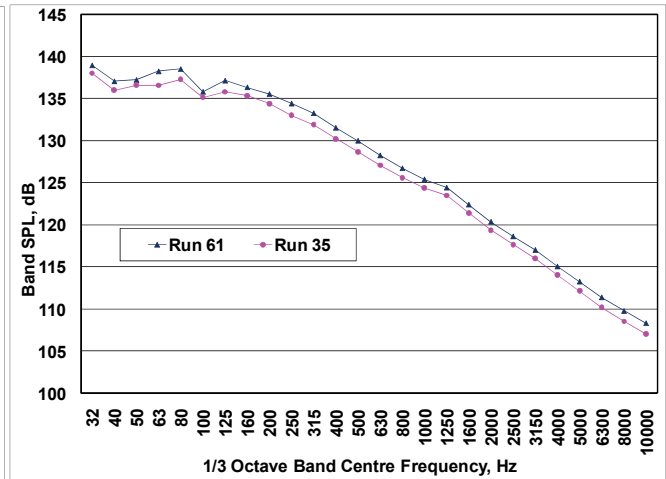

(f) Repeatability Test, trial 2

Figure 9: The behavior of MK-VII Modulator.

### 5.1.4 MK-VI Modulator Dynamic Range

The achievable dynamic range of a modulator is an important parameter that contributes to the complexity of the modulator layout required during a test program. A test program for a given test article invariably consists of testing to a series of spectral targets ranging from 15 dB below flight levels to in some cases several dB above. If a given modulator does not have sufficient dynamic range, a number of modulator configurations employing a varying number of modulators is required to encompass the range of spectral targets; the lower the dynamic range of a given modulator, the greater the number of required configurations.

Three spectral shapes were applied to characterize the dynamic range of the modulator. The results are shown in Figure 10 for two of the spectral shapes. The key observation is that the dynamic range that can be obtained for the MK-VI modulator is between 6 and 9 dB. Note that the dynamic range was found to be dependent on the input signal spectral shape.

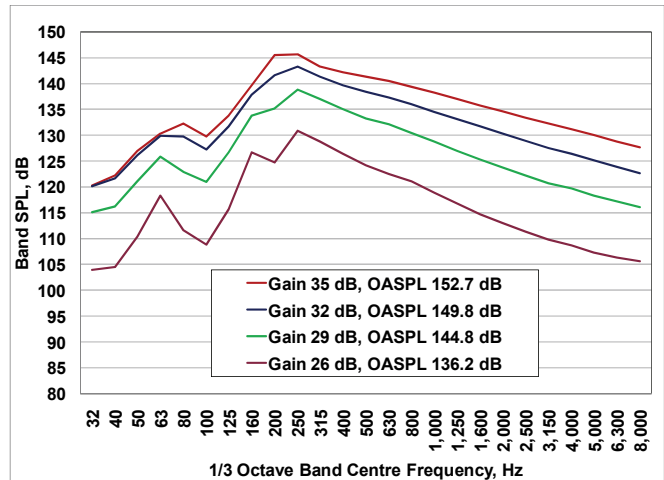
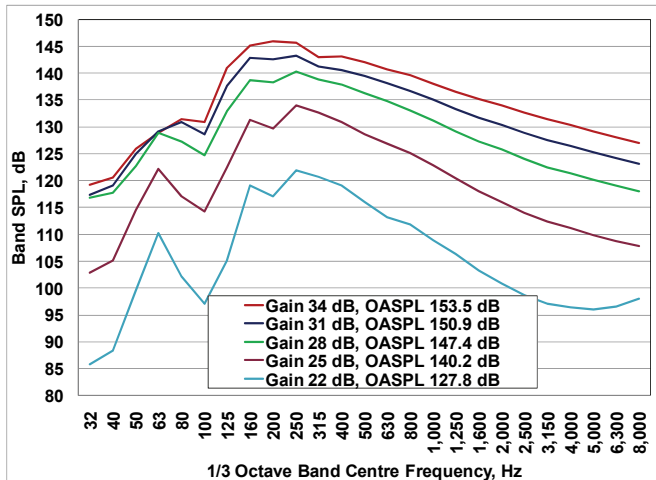

Figure 10: The Dynamic Range of MK-VI Modulator.

### 5.1.5 MK-VII Modulator Dynamic Range

Three spectral shapes were also applied to test the dynamic range of the modulator, and the results are shown in Figure 11 for two input spectral shapes. For the MK-VII modulator, the dynamic range is between 9 and 12 dB. As was the case with the MK-VI, the measured dynamic range is dependent on the spectral shape of the input signal.

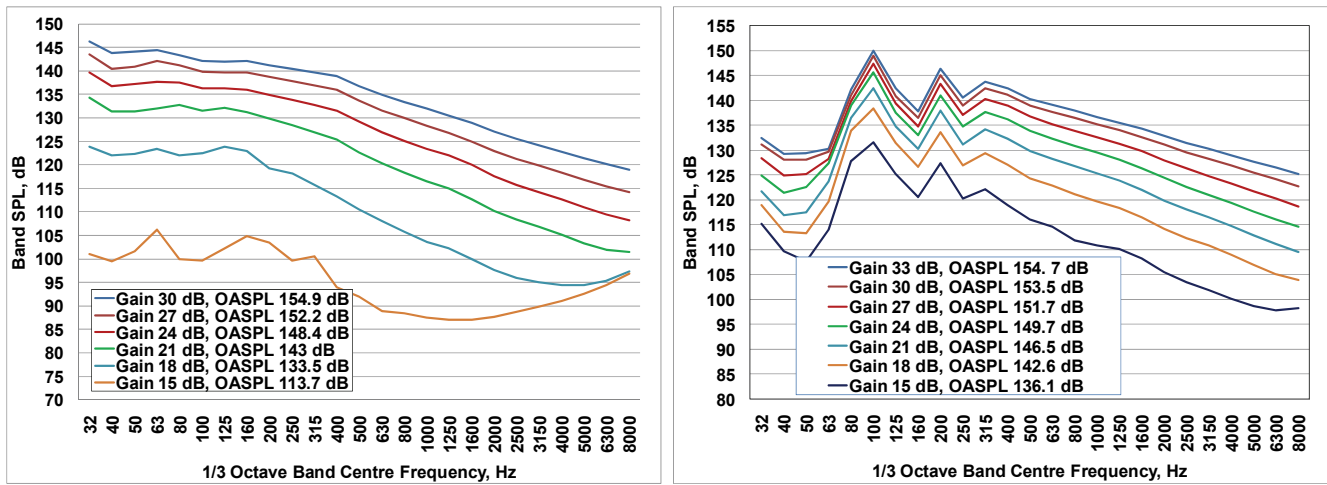

Figure 11: The Dynamic Range of MK-VII Modulator.

## 5.2 Controllability Test Results

The closed loop control for reverberant chamber acoustic spectrum control essentially involves applying an array of feedback loops to control the attenuation values of a bank of 1/3-octave filters. In typical control operations, the initial attenuation factors for each 1/3-octave frequency band would be pre-determined during an empty chamber calibration test to allow for quick convergence once the test article is placed in the chamber.

Since the initial attenuation factors were not known a priori for each test spectrum, the current control testing is to be considered as calibration mode testing, where large attenuation factors were used to begin the test. The above process was applied so that the noise levels do not overshoot the target sound levels. Five spectral shapes, each scaled to meet the achievable overall sound pressure levels in the NRC chamber with a single Team modulator, were used for the testing. Furthermore, the controllable frequency range for the chosen shape was adjusted to be within the operational range of the chosen modulator-horn combination. For example, the controllable range for the MK-VII on the 25 Hz horn is 31.5 Hz to 500 Hz. Similarly, the controllable range for the MK-VI on the 160 Hz horn is 125 Hz to 500 Hz.

The following process was applied:

- one of the chosen spectra was applied to the controller with the attenuators set at 100 dB below the target levels
- the controller was started
- the modulator takes a few seconds to initiate and once initiated it quickly rises to meet the target.
- The average of six microphone signals was used as the control parameter.

The time signals of all the microphones as well as the control signal, i.e., the six-microphone average, were recorded for at least two minutes after stabilization of the overall signal.

### 5.2.1 MK-VI Modulator Controllability

The results of the closed loop control tests for the MK-VI on the 160 Hz horn are presented as a time history to evaluate the rise time as well as the steady state statistics after the signal stabilizes to the set target. The average, standard deviation, deviation to maximum point, and deviation to minimum point were evaluated from the point of stabilization to the end of recording of that test. The results are shown in Figure 12 for one of the spectra tested.

For this specific closed loop test, the rise time is in the range of 25 to 35 seconds. Note: these rise times only represent those expected during initial empty chamber tests for a given spectrum. Once the appropriate attenuation factors are then applied for the actual test, these rise times would be reduced. The signal is seen to be reasonably steady with the standard error of one dB or less for most cases.

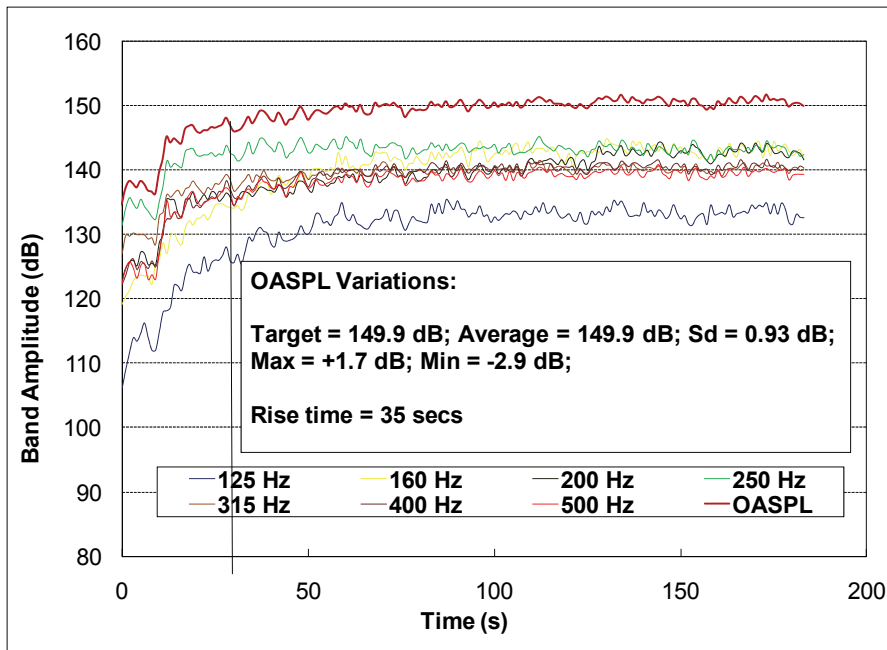

Figure 12: Closed Loop testing of MK-VI Modulator

### 5.2.2 MK-VII Modulator Controllability

The results of the closed loop control tests for the MK-VII on the 25 Hz horn are presented as a time history to evaluate the rise time as well as the basic statistics after the signal stabilizes to the set target. The average, standard deviation, deviation to Maximum point, and deviation to Minimum point were evaluated from the stabilization point to the end of recording of that test. The results are shown in Figure 13 for one of the spectra tested.

Once again, the rise time is in the range of 25 to 35 seconds and as was the case with the MK-VI, these are the rise times from a large attenuation initial state. Calibration runs will be employed to determine appropriate initial conditions for the controller to facilitate a much quicker response time. The steady state performance of the MK-VII in this case is slightly improved over the case presented for the MK-VI earlier.

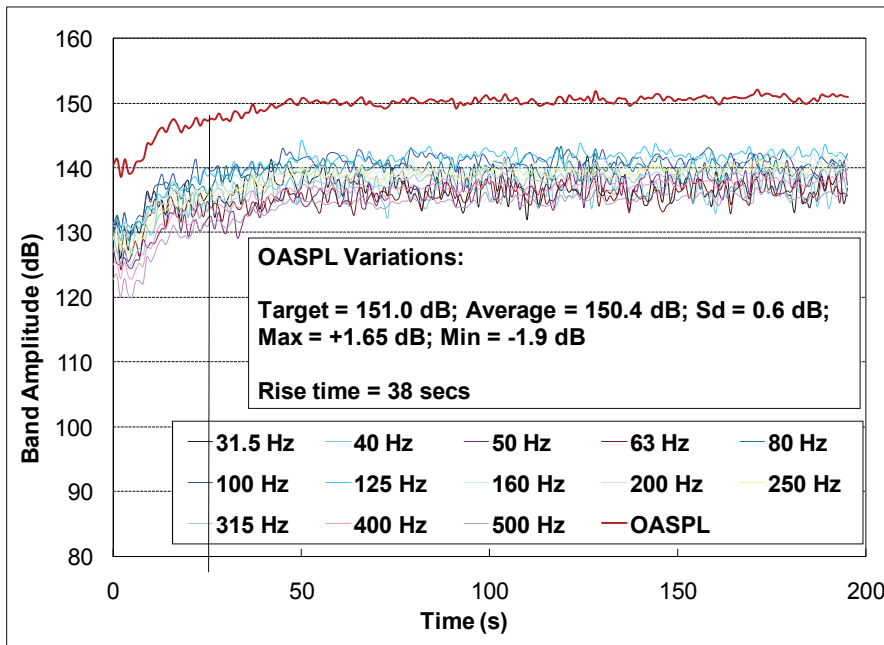

Figure 13: Closed Loop testing of MK-VII Modulator

## 6.0 CONCLUSIONS

An operational need for the design and development of a very large reverberant acoustic test facility at NASA Glenn Research Center with an extremely high acoustic power requirement necessitated the careful examination of the acoustic output power of available noise generators. Two models of modulators supplied by Team Corporation appeared to have the necessary acoustic output and frequency characteristics. However, a detailed characterization of these modulators was necessary to mitigate the risk of the proposed chamber design. Consequently, a series of test programs were performed that in addition to characterizing the generated noise, also examined the controllability, dynamic range and the optimal performance region of the modulator.

The test program was performed at the NRC-IAR reverberant chamber, located in Ottawa, Ontario, Canada and demonstrated that the modulators were capable of producing their rated acoustic power (150 kW for the Team MK-VI and 200 kW for the MK-VII), and had a dynamic range of between 6 and 9 dB for the MK-VI, and between 9 and 12 for the MK-VII. Furthermore, both modulators exhibited excellent repeatability and sufficiently controllability to allow for their control via currently available acoustic control systems.

## 7.0 ACKNOWLEDGEMENTS

The authors would like to acknowledge the contribution of their colleagues during the test program. In particular the NRC authors would like to thank Luc Hurtubise, Brent Lawrie, Viresh Wickramasinghe, David Zimcik, Sebastian Ghinet and Manouchehr Nejad-Ensan for their effort during the various test phases. Aiolos Engineering Corp would like to thank the engineering team members of Aiolos and Benham, headed up by Ralph Leitner and Neil Waggoner, respectively, for their many contributions to making this test program happen. The NASA author would like to acknowledge the NASA SET Project Office for their support and funding for this test program. He would also like to acknowledge the extensive and valuable engineering test support provided by Aron Hozman, Anne McNelis, and Mark McNelis from NASA GRC, and Dr. Jerome Manning and Dr. Patricia Manning from Cambridge Collaborative Incorporated. Team would like to acknowledge and thank Bob Tauscher from Team and Neil Waggoner from Benham.

## 8.0 REFERENCES

1. Hughes, W.O., McNelis, M.E., Hozman, A.D., and McNelis, A.M., "Status and Design Features of the new NASA GRC Reverberant Acoustic Test Facility (RATF)", *Proceedings of the 2010 IEST Annual Technical Meeting, ESTEC 2010*, 3-6 May 2010, Reno, NV, USA.
2. Otten, K.D., Suarez, V.J. , and Le, D.K., "Status and Design Features of the new NASA GRC Mechanical Vibration Facility (MVF)", *Proceedings of the 2010 IEST Annual Technical Meeting, ESTEC 2010*, 3-6 May 2010, Reno, NV, USA.
3. Hughes, W.O., McNelis, M.E., Hozman, A.D., McNelis, A.M., "The Testing Behind the Test Facility: The Acoustic Design of the NASA Glenn Research Center's World-Class Reverberant Acoustic Test Facility", NASA/TM-2010-216802, October 2010.
4. Fiala, W.T., Hilliard, J.K., Renkus, J.A., Van Houten, J.J., "Electropneumatic Acoustic Generator", *Journal of the Acoustical Society of America*, Volume 38, Issue 6, pp. 956-964, December 1965.
5. Kuttruff, H., *Room Acoustics*, 3<sup>rd</sup> Edition, Elsevier, London, 1991.